



Review

Roadmap to a net-zero carbon cement sector: Strategies, innovations and policy imperatives

Salim Barbhuiya^{a,*}, Bibhuti Bhusan Das^b, Dibyendu Adak^c^a Department of Engineering and Construction, University of East London, UK^b Department of Civil Engineering, NIT Karnataka, Surathkal, India^c Department of Civil Engineering, NIT Meghalaya, Shillong, India

ARTICLE INFO

Keywords:

Net-zero carbon
Cement industry
Low-CO₂ technologies
Climate change
Sustainability

ABSTRACT

The cement industry plays a significant role in global carbon emissions, underscoring the urgent need for measures to transition it toward a net-zero carbon footprint. This paper presents a detailed plan to this end, examining the current state of the cement sector, its carbon output, and the imperative for emission reduction. It delves into various low-CO₂ technologies and emerging innovations such as alkali-activated cements, calcium looping, electrification, and bio-inspired materials. Economic and policy factors, including cost assessments and governmental regulations, are considered alongside challenges and potential solutions. Concluding with future prospects, the paper offers recommendations for policymakers, industry players, and researchers, highlighting the roadmap's critical role in achieving a carbon-neutral cement sector.

1. Introduction

The cement industry, a cornerstone of global development, is central to the construction of essential infrastructure for societies worldwide. However, its intensive carbon footprint poses a significant challenge, necessitating a transition towards a net-zero carbon cement sector. Cement production involves a complex process wherein raw materials like limestone, clay, and other substances are heated to high temperatures to produce clinker, the main component of cement. This process is energy-intensive and primarily relies on fossil fuels, leading to substantial CO₂ emissions. The emissions stem from both the chemical reactions involved in transforming raw materials into clinker and the combustion of fossil fuels to achieve the necessary high temperatures. Consequently, the cement industry contributes to approximately 7–8% of the total global CO₂ emissions, making it a major contributor to climate change (Madloul et al., 2011; Oh et al., 2014; Proaño et al., 2020; Amran et al., 2022).

The environmental consequences of CO₂ emissions are profound and are linked to various adverse impacts associated with climate change. Rising global temperatures, altered precipitation patterns, more frequent and severe weather events, sea-level rise, and disruptions in ecosystems are just a few of the consequences of climate change (Hellmann et al., 2008; Khoshnevis Yazdi and Shakouri, 2010; Osland et al.,

2016). Addressing the cement industry's significant carbon emissions is critical in mitigating these impacts and working towards global sustainability. The urgency to combat climate change has led to a global consensus on the need to reduce carbon emissions and transition to a net-zero carbon future. The Paris Agreement, a landmark international treaty, outlines the collective efforts required to limit global warming to well below 2 °C above pre-industrial levels, with an ambitious target of aiming for a 1.5-degree limit (Rogelj et al., 2016; Rogelj et al., 2019; Meinshausen et al., 2022). Achieving these goals necessitates significant emissions reductions across all sectors, including cement production.

A net-zero carbon cement sector is a crucial step towards meeting these global climate goals. It involves adopting a holistic approach that encompasses implementing low-CO₂ emission technologies, utilizing sustainable and alternative raw materials, enhancing energy efficiency, and exploring carbon capture and storage solutions. Such a transition aligns the cement industry with the broader global ambition to achieve a sustainable and low-carbon future. Furthermore, embracing a net-zero carbon cement sector carries substantial economic and social benefits (Rissman et al., 2020; Panos et al., 2023). It drives innovation, stimulates research and development of cutting-edge technologies, and creates a market for sustainable products and practices. The transition fosters a resilient economy, encourages green investments, and contributes to the creation of green jobs, supporting long-term economic

* Corresponding author.

E-mail address: s.barbhuiya@uel.ac.uk (S. Barbhuiya).

growth while safeguarding the environment. The journey towards a net-zero carbon cement sector is essential in addressing climate change, reducing global CO₂ emissions, and promoting sustainability (Amran et al., 2022; Tan et al., 2022; Ren et al., 2023). The benefits extend beyond environmental stewardship, positively impacting economies and societies, making this transition a critical imperative for a sustainable future.

The motivation for this paper lies in addressing the urgent environmental crisis posed by the cement industry's significant carbon emissions. By focusing on a net-zero carbon cement sector, the aim is to align with global sustainability goals, particularly combating climate change as outlined in the Paris Agreement. This work strives to integrate advancements in low-CO₂ technologies and policy frameworks, emphasizing economic viability and encouraging collaborative efforts. Ultimately, the objective is to educate diverse stakeholders and drive sustainable practices, fostering a resilient economy while ensuring a sustainable and habitable future for generations to come. This paper meticulously examines the cement industry's carbon emissions and the pressing need for environmental mitigation. It assesses current emissions, explores low-CO₂ technologies, and evaluates economic and policy influences. Offering actionable recommendations, it emphasizes collaborative efforts to transition towards a net-zero carbon cement sector. Highlighting the industry's pivotal role in climate change, it advocates for concerted action among stakeholders to achieve sustainability goals.

The novelty of this paper lies in its comprehensive roadmap towards achieving a net-zero carbon cement sector. It analyses the current state of the cement industry, highlighting its substantial carbon footprint and the imperative for emission reduction. Unique insights are provided into various low-CO₂ technologies and emerging innovations, such as alkali-activated cements and calcium looping. Economic and policy considerations, including cost assessments and governmental regulations, are thoroughly examined, offering a holistic approach to addressing the challenges faced by the industry. By integrating advancements in technology and policy frameworks, this paper provides actionable recommendations for policymakers, industry players, and researchers, emphasizing the critical role of collaboration in transitioning towards a sustainable future.

The paper proposes a detailed roadmap for achieving net-zero carbon emissions in the cement industry. Unlike Guo et al.'s (2024) review of low-carbon technologies, Ali et al.'s (2011) emission analysis focus, and Chaudhury et al.'s (2023) strategies, it offers a comprehensive plan. It covers current industry status, emission reduction imperatives, and various low-CO₂ technologies. Economic, policy, and technological factors are analysed, alongside challenges and potential solutions. Recommendations target policymakers, industry stakeholders, and researchers. This paper stands out for its holistic approach, providing a clear pathway towards a carbon-neutral cement sector, distinct from the broader reviews and specific strategies outlined in the other papers.

Section 2 is on methodology. Section 3 is understanding the cement industry's impact on climate change encompasses key aspects crucial for addressing emissions. It delves into the carbon-intensive nature of cement production and stresses the urgent need to mitigate carbon emissions within the sector. Furthermore, it outlines various global initiatives and policies driving carbon reduction efforts, including the Paris Agreement and NDCs, carbon pricing mechanisms, industry-led challenges like Mission Innovation, sustainability charters such as the GCCA, innovative projects like LEILAC, collaborative initiatives like the WBCSD CSI, technology roadmaps like the IEA's, and governmental regulations and policies. Section 4 explores low-CO₂ emission technologies vital for reducing the environmental impact of cement production. Section 5 delves into innovative approaches and emerging technologies shaping the future of cement production. Section 5 explores innovative approaches and emerging technologies in cement production, including alkali-activated cements, the calcium looping process, electrification, renewable energy integration, and biomimicry and bio-inspired

cementitious materials, all aiming to reduce environmental impact and promote sustainability. Section 6 explores the economic and policy landscape necessary for transitioning towards a net-zero carbon cement sector. Section 7 addresses the hurdles hindering the adoption of low-CO₂ technologies in cement production. Technical challenges encompass scalability, efficiency, and compatibility with existing infrastructure. Infrastructure and investment barriers include the lack of necessary facilities and uncertain market conditions, impeding progress. Section 8 outlines future prospects and recommendations crucial for advancing the cement industry towards sustainability.

2. Methodology

In the current study, a comprehensive approach known as a systematic literature review (SLR) is employed to thoroughly investigate and evaluate the net-zero carbon in cement sector. This method involves a systematic and organized review of existing literature to gather insights into the subject. The review process is depicted in the framework presented in Fig. 1.

To conduct this literature review, widely recognized bibliometric databases such as Scopus, Web of Science, and Google Scholar were utilised. The search strategy involved the use of specific keywords related to the topic, including phrases like "net-zero carbon," "cement sector," and "Low-CO₂ technologies." These keywords were chosen to ensure a comprehensive exploration of relevant research on the subject. The subsequent steps involved a thorough examination and analysis of the identified research papers. The goal was to filter out studies that were most relevant to net-zero carbon in cement sector. The selection process considered the quality, relevance, and significance of each paper, resulting in a compilation of research findings that contribute to a deeper understanding of net-zero carbon in cement sector. This systematic and structured approach ensures a rigorous review, offering valuable insights into the current state of knowledge on the net-zero carbon in cement sector.

In this paper a rigorous methodology was employed to gather and analyse relevant literature concerning the cement sector's transition to a net-zero carbon footprint. Through systematic review and synthesis, we effectively utilised 134 articles to support our examination of the industry's current state, carbon emissions, and strategies for emission reduction. The paper utilised stringent inclusion criteria, focusing on recent, peer-reviewed literature relevant to the cement industry's carbon reduction. Articles addressing emission mitigation, technological innovations, policy frameworks, and economic considerations were prioritized. Geographic diversity ensured regional insights. Methodological rigor and academic credibility guided selection, emphasizing empirical evidence and theoretical frameworks. This approach ensured a comprehensive, up-to-date analysis, fostering actionable recommendations for policymakers, industry stakeholders, and researchers.

3. Understanding the cement industry and climate change

The cement industry stands as a substantial contributor to global climate change due to its colossal carbon emissions. Cement production, a process involving high-temperature kilns, emits CO₂ both from chemical reactions and energy-intensive fuel combustion. This industry constitutes about 7–8% of global CO₂ emissions, a glaring concern for climate mitigation efforts. The released CO₂ exacerbates the greenhouse effect, leading to global warming and its dire repercussions—extreme weather patterns, rising sea levels, and ecosystem disruptions. Addressing the cement industry's carbon footprint is essential for a sustainable future, necessitating urgent adoption of low-CO₂ technologies and a transition to a net-zero carbon cement sector.

3.1. Cement production and its carbon footprint

Cement production, a vital industry supporting global infrastructural

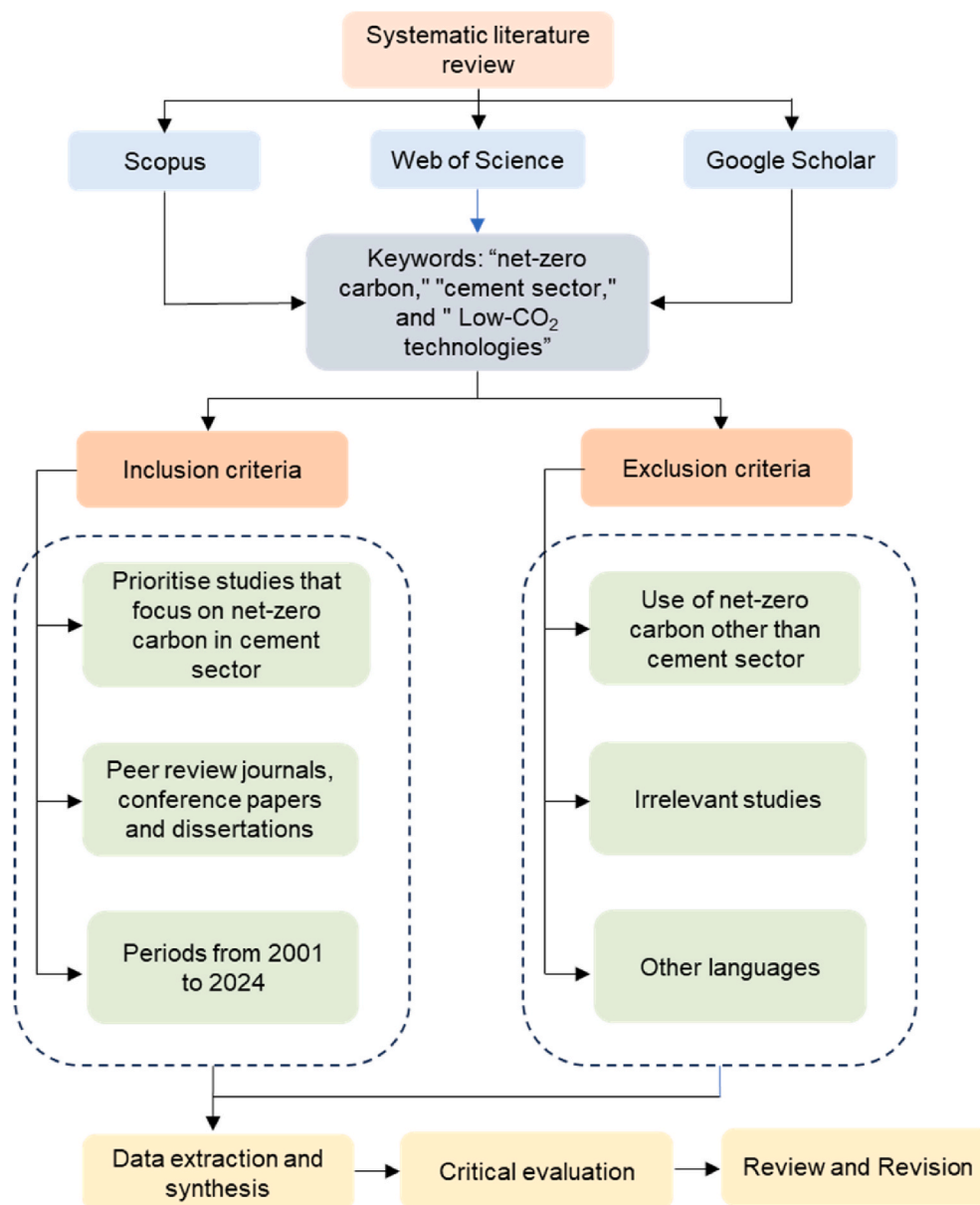
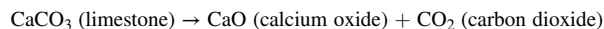

Fig. 1. Systematic literature review methodology.

development, possesses a considerable carbon footprint due to its intrinsic manufacturing process. The carbon footprint signifies the total amount of greenhouse gases, particularly CO₂, and other emissions that are released into the atmosphere as a result of human activities, in this case, cement production. This footprint is a key indicator of the environmental impact associated with cement manufacturing and its significant role in climate change.

The cement production process is initiated with the extraction and processing of raw materials, including limestone, clay, shale, and other supplementary materials (Schneider et al., 2011; Gao et al., 2016). These materials are extracted from quarries and undergo crushing and fine grinding to create a homogeneous raw material mix known as raw meal. The composition of the raw meal is crucial in determining the properties of the resulting clinker and, consequently, the quality of cement. The heart of cement production lies in the kiln, a high-temperature, energy-intensive furnace. The prepared raw meal is fed into the kiln, where it undergoes a series of complex physical and chemical transformations (Wang et al., 2006; Rahman et al., 2015; Ishak and Hashim, 2015). At temperatures exceeding 1450 °C, the raw meal

reacts to form clinker, a sintered nodular material. The critical chemical reaction in this process involves the decomposition of calcium carbonate (CaCO₃), which is a fundamental contributor to the carbon footprint of cement production. This reaction releases CO₂ as a by-product. Fig. 2 shows the schematic representation of cement production. The chemical reaction during clinker production can be summarised as follows:



Energy consumption is a crucial aspect of cement production. Traditional kilns primarily use fossil fuels like coal, oil, or natural gas, which release substantial CO₂ emissions during combustion (Liu et al., 2007; Shen et al., 2014; Oberschelp et al., 2023). This energy-intensive process significantly contributes to the industry's overall carbon footprint. After clinker production, the resulting clinker is finely ground with gypsum and additives to produce cement. Although the grinding process itself does not directly emit CO₂, it consumes a considerable amount of energy, often sourced from fossil fuel-based power plants. This indirect energy consumption adds to the industry's carbon footprint. The carbon footprint varies depending on factors such as the type

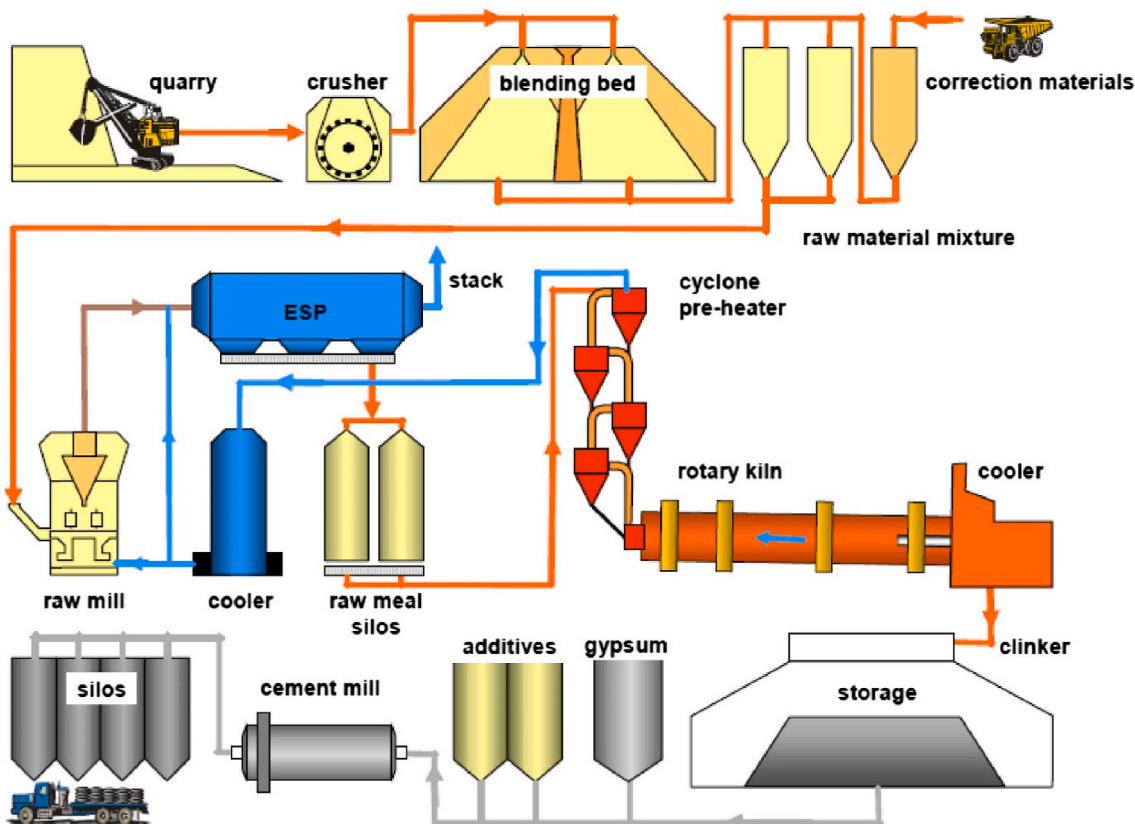

Fig. 2. Schematic representation of cement production (Lamas et al., 2013).

of kiln used, energy efficiency measures, fuel types, and efficiency of clinker grinding (Cagiao et al., 2011; Ali et al., 2011; Xu et al., 2013).

Table 1 provides a general overview and may vary based on specific production methods and technological advancements. The amount of CO₂ emissions per ton in raw material processing for cement production can vary depending on several factors including the type of raw materials used, the energy sources utilised in the process, and the efficiency of the production methods. However, as a general estimate, raw material processing in cement production can emit around 0.8–1.0 tons of CO₂ per ton of cement produced. This figure includes emissions from activities such as quarrying, crushing, grinding, and transporting raw materials. It's important to note that advancements in technology and sustainable practices within the cement industry are aiming to reduce these emissions over time.

In clinker production, which is a key stage in cement manufacturing, CO₂ emissions are primarily generated from the calcination process, where limestone (calcium carbonate) is heated to produce lime (calcium oxide) and CO₂. The average amount of CO₂ emissions per ton of clinker produced varies depending on factors such as the specific technology used, the energy sources utilised (e.g., fossil fuels, alternative fuels), and the efficiency of the production process. However, as a general estimate, clinker production typically emits around 0.6–0.8 tons of CO₂ per ton of

clinker produced. It is worth noting that the cement industry is actively working on improving energy efficiency, implementing alternative fuels, and exploring carbon capture and storage (CCS) technologies to reduce CO₂ emissions associated with clinker production. These efforts are aimed at mitigating the environmental impact of cement manufacturing.

The CO₂ emissions associated with clinker grinding are generally much lower compared to those from clinker production itself. Clinker grinding involves the process of grinding clinker nodules (produced in the kiln) with gypsum to produce cement. The amount of CO₂ emissions per ton in clinker grinding depends on various factors such as the energy source used for grinding (e.g., electricity, fossil fuels), the efficiency of the grinding process, and any supplementary materials added during the grinding stage. As a rough estimate, the CO₂ emissions from clinker grinding are typically around 0.1–0.3 tons of CO₂ per ton of cement produced. However, these figures can vary widely depending on the specific circumstances of the grinding operation and any measures taken to reduce emissions. Efforts to reduce emissions from clinker grinding may include using more energy-efficient grinding technologies, optimizing process parameters, and using supplementary cementitious materials (SCMs) to replace some portion of the clinker, which can lower the overall CO₂ footprint of cement production.

Mitigating the carbon footprint of cement production involves several strategies. One crucial approach is the integration of alternative raw materials and fuels, which can reduce the clinker-to-cement ratio and decrease the reliance on fossil fuels (Pardo et al., 2011; Schneider, 2015). Additionally, implementing carbon capture, utilization, and storage (CCUS) technologies shows promise in capturing CO₂ emissions from cement production before they are released into the atmosphere (Plaza et al., 2020; Guo et al., 2024). Energy efficiency improvements and waste heat recovery are essential in reducing energy demand and, consequently, the carbon footprint.

Innovative approaches to clinker production, such as using

Table 1
Carbon footprint of different stages in cement production.

Stage in Cement Production	Carbon Footprint	CO ₂ emission/ton
Raw Material Processing	Moderate (energy for grinding and preparation)	0.8–1.0
Clinker Production	High (due to calcination and fossil fuel use)	0.6–0.8
Clinker Grinding and Cement Production	Moderate to High (energy for grinding)	0.1–0.3

alternative binders or advanced kiln designs, hold potential in minimizing high-temperature requirements and reducing CO₂ emissions. Furthermore, embracing circular economy practices by utilizing waste materials in cement production promotes sustainability and lessens the industry's dependence on virgin resources (Mokrzycki and Uliasz-Bochenczyk, 2003; Hossain et al., 2017; Ighalo and Adeniyi, 2020; Norouzi et al., 2021). Policy and regulatory measures play a pivotal role in incentivizing the adoption of low-carbon technologies and sustainable practices within the cement sector. Governments and industry associations need to enforce stringent regulations that align with global sustainability goals, driving meaningful change within the industry and fostering a culture of environmental responsibility.

3.2. The urgency of addressing carbon emissions in the cement sector

The urgency to address carbon emissions in the cement sector stems from its immense role in global greenhouse gas emissions and its consequent impact on climate change. Cement production is fundamentally carbon-intensive, with a significant portion of its emissions arising during the calcination process. Throughout this process, limestone undergoes a chemical change that releases CO₂, accounting for a significant portion of the overall CO₂ emissions linked to cement manufacturing. These emissions pose a considerable challenge to endeavours aimed at mitigating climate change.

Based on global CO₂ emission data, cement plants significantly escalated their contribution to carbon emissions, reaching 2.9 billion tons in 2021, a nearly fivefold increase compared to 0.57 billion tons in 1990 (Benhelal et al., 2013; Science & Nature, 2022). Notably, from 2006 to 2021, the primary CO₂-emitting countries were China, India, Europe, and the United States (Hanifa et al., 2023). Specifically, the Indian cement industry witnessed a substantial rise, producing around 149 million tons of CO₂ in 2021, a nearly sevenfold increase from 22.35 million tons in 1990 (Fig. 3) (Global Carbon Project, 2022). Scientific reports stress achieving net-zero emissions globally by the century's end to align with the Paris Agreement Goals. To meet this objective, comprehensive strategies are being developed across various sectors, encompassing cement and concrete production, as well as the efficient utilization of cement-based materials (Hanifa et al., 2023; Huovila et al., 2022; Lima et al., 2021; Mart in Schneider, 2019).

The scale of cement production is vast, driven by the escalating demand fuelled by urbanization, population growth, and infrastructure development. Consequently, the carbon footprint of the cement sector is extensive and has far-reaching consequences. Predictions by the

International Energy Agency (IEA) indicate that without substantial interventions, the cement industry could contribute to about 13% of global CO₂ emissions by 2050, underscoring the urgent need to act (Dhar et al., 2020; Obrist et al., 2021; Mishra et al., 2022). Moreover, structures built with cement have a long-life span, and the carbon emissions associated with them endure for many decades. This longevity implies that the carbon footprint of the sector has long-term implications. As a result, addressing carbon emissions promptly is crucial to avoid the lock-in of high levels of CO₂ emissions from both existing and future structures.

The global environmental impact of the cement sector's carbon emissions cannot be overstated. These emissions significantly contribute to global warming and climate change, resulting in detrimental environmental effects including altered precipitation patterns, extreme weather events, and rising sea levels. Addressing these emissions is imperative to mitigate these impacts and protect the environment. Aligned with international climate agreements such as the Paris Agreement, the urgency to reduce carbon emissions in the cement sector is essential to meet global climate objectives (Mahasenan et al., 2003; Rehan and Nehdi, 2005; Rasheed et al., 2022). This urgency is intensified by the rapid advancements in low-carbon technologies and sustainable practices, making it economically viable to transition to a more sustainable future for the cement industry. Consumer awareness of the environmental repercussions of cement production is burgeoning. Consumers, industries, and governments are increasingly advocating for sustainable practices, creating a shift towards low-carbon alternatives in cement production. This growing awareness amplifies the urgency to address carbon emissions, highlighting the need for immediate and sustained action.

3.3. Global initiatives and policies for carbon reduction in cement production

In response to the escalating concern regarding climate change and the urgent need to mitigate carbon emissions, global initiatives and policies targeted at reducing carbon emissions in the cement sector have gained prominence. The cement industry, a major contributor to global greenhouse gas emissions, is a critical sector to address in order to achieve international climate goals and transition to a low-carbon future. Several key global initiatives and policies have been developed to drive carbon reduction in cement production.

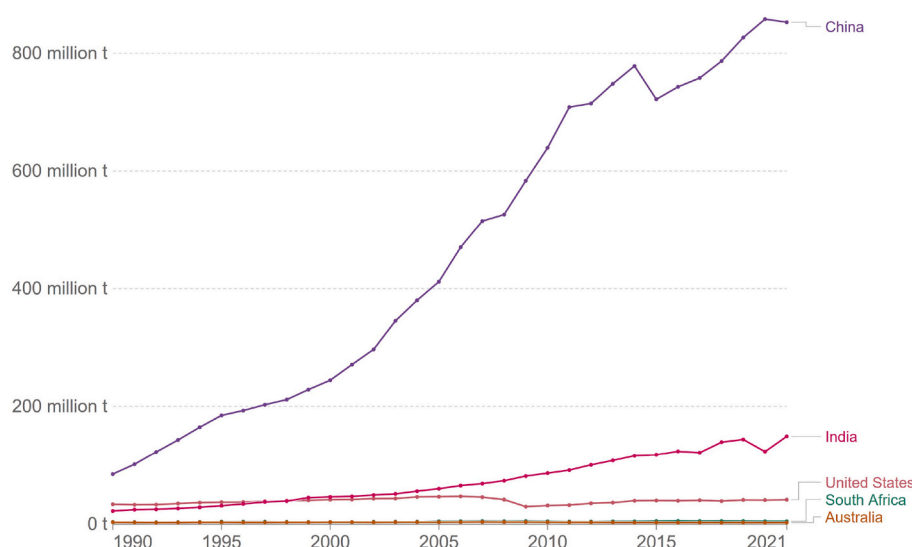

Fig. 3. Global CO₂ emission from cement production (Global Carbon Project, 2022).

3.3.1. Paris Agreement and Nationally Determined Contributions (NDCs)

The Paris Agreement, adopted in 2015 during the 21st UNFCCC Conference of Parties (COP21), is a pivotal international accord that sets the framework for global efforts to combat climate change. The agreement aims to limit global warming to well below 2 °C and pursue efforts to restrict it to 1.5 °C (Schleussner et al., 2016). The cornerstone of the Paris Agreement is the submission of Nationally Determined Contributions (NDCs) by each participating country. NDCs are essentially individual commitments made by signatory nations, outlining their specific strategies and targets for reducing greenhouse gas emissions and fostering sustainable development within their respective countries. These contributions are designed to reflect each nation's unique circumstances, capabilities, and responsibilities, acknowledging the common but differentiated responsibilities and respective capabilities (CBDR-RC) principle.

For the cement sector, an industry that is a significant contributor to global greenhouse gas emissions, the Paris Agreement necessitates a strategic re-evaluation and recalibration of its operations. The cement sector plays a crucial role in global infrastructure development and is indispensable for modern construction and urbanisation. However, its traditional manufacturing processes, often reliant on carbon-intensive practices, have led to substantial emissions of CO₂ and other greenhouse gases. To align with the commitments laid out in their NDCs, countries need to strategically target the cement sector. This includes setting emission reduction targets specific to cement production, embracing and implementing innovative, sustainable practices, and investing in research and technology that minimise the carbon footprint of cement production. Strategies might include deploying carbon capture and storage technologies, adopting low-carbon alternative materials and fuels, enhancing energy efficiency in the manufacturing process, and promoting circular economy practices within the industry.

In essence, the Paris Agreement has effectively set the stage for transformative change within the cement sector. It has induced a paradigm shift, compelling nations and industry stakeholders to proactively tackle the carbon emissions associated with cement production. Moreover, it has fostered a sense of collective responsibility, encouraging international collaboration and knowledge sharing to accelerate the transition towards sustainable cement manufacturing. Through ambitious targets, diligent monitoring, and continuous improvement, the cement sector can significantly contribute to the broader objectives of the Paris Agreement, ultimately advancing the global mission to combat climate change and safeguard the environment for future generations.

3.3.2. Carbon pricing and Emissions Trading Systems (ETS)

Carbon pricing and Emissions Trading Systems (ETS) are innovative economic approaches aimed at addressing climate change by internalising the cost of carbon emissions in economic activities. These mechanisms incentivize emission reductions and encourage the transition towards sustainable practices. Carbon pricing involves assigning a monetary value to the carbon content of fossil fuels or the amount of CO₂ emitted. There are two main methods: carbon tax and cap-and-trade systems (Carl and Fedor, 2016; Chen et al., 2020). A carbon tax is a direct levy imposed on the carbon content of fossil fuels or on actual CO₂ emissions. It incentivizes emission reduction by putting a financial burden on companies based on their emissions. On the other hand, the cap-and-trade system sets a limit or cap on total allowable emissions. Permits representing specific emission amounts are traded in a regulated market. Over time, the emission cap is reduced, driving down overall emissions.

Emissions Trading Systems (ETS) provide flexibility to industries in emission reductions (Zhao et al., 2016; Narassimhan et al., 2018; Li et al., 2021). Permits can be bought, sold, or traded, promoting cost-efficient emission reduction strategies. Emission allowances are distributed based on various criteria, and companies exceeding their allocation must purchase additional permits (Paolella and Taschini, 2008; Khaqqi et al., 2018). The total emission cap is periodically

reduced, pushing industries to achieve emission reductions progressively. The benefits of these mechanisms are substantial. Carbon pricing encourages emission reductions and investments in cleaner technologies while providing revenue for governments to reinvest in sustainability. ETS, in particular, promotes flexibility and cost-effectiveness in emissions reduction, helping countries meet climate targets. However, challenges include initial implementation hurdles, market manipulation risks, and concerns about the impact on certain industries.

3.3.3. Mission Innovation - Cement Challenge

Mission Innovation, a worldwide initiative involving 24 countries and the European Commission, represents a collective commitment to propel advancements in clean energy technologies (Gielen et al., 2016; Oberthür et al., 2021). At its core, this initiative is a response to the critical need for innovative and sustainable solutions to combat climate change by accelerating the pace of innovation in clean energy. Within Mission Innovation, the "Cement Challenge" holds particular significance, acknowledging the vital role of the cement industry in global greenhouse gas emissions.

The Cement Challenge is a focused endeavour within Mission Innovation, highlighting the urgent necessity to revolutionize cement production technologies. Cement production is inherently carbon-intensive, being a major contributor to CO₂ emissions due to the calcination process during clinker production. Hence, transforming conventional cement production methods is crucial to align with sustainability objectives. The paramount objective of the Cement Challenge is to drive innovation in cement production technologies. This involves harnessing research, development, and global collaboration to significantly reduce CO₂ emissions while ensuring that the cement's performance and functionality are either maintained or improved.

Innovation in technology is a central pillar of the Cement Challenge. The initiative encourages the development and implementation of pioneering technologies that can reshape how cement is produced. These innovations could encompass new manufacturing processes, sophisticated kiln designs, optimised selection of raw materials, or the integration of carbon capture and storage technologies. A pivotal focus of the Cement Challenge is to achieve substantial reductions in CO₂ emissions from cement production. By identifying and employing low-carbon and carbon-neutral technologies, the challenge aims to mitigate the industry's significant contribution to global greenhouse gas emissions.

Balanced with emissions reduction is the imperative to enhance the performance of cement. Innovations pursued under the Cement Challenge must ensure that the resulting cement meets industry standards and can perform its intended functions effectively in various construction applications. Collaboration stands at the core of the Cement Challenge. The initiative promotes collaboration among nations, researchers, academia, and industry stakeholders. By fostering a global network of knowledge and expertise, the challenge facilitates the exchange of ideas, research findings, and best practices to drive forward sustainable and innovative solutions. Furthermore, the Cement Challenge has a long-term vision of sustainable impact. It is not just about immediate solutions but about fostering lasting, sustainable change. By encouraging research and innovation, the initiative aims to transform the cement industry into a low-carbon, environmentally responsible sector that can thrive in the future while contributing to global climate goals.

Table 2 provides a concise overview of the goals, methods, and collaborative nature of the Cement Challenge within Mission Innovation, emphasizing its role in transforming the cement industry for a more sustainable future. The table encapsulates the core aspects of the Cement Challenge within Mission Innovation, a global initiative focused on revolutionizing cement production to combat climate change. Highlighting the urgency to reduce carbon emissions from the cement industry, the challenge centres on innovative technologies and processes. It aims to maintain or enhance cement performance while significantly lowering CO₂ emissions. Collaboration is key, fostering a global network

Table 2
Key aspects of the cement challenge within mission innovation.

Aspect	Cement Challenge within Mission Innovation
Objective	Drive innovation in cement production technologies to significantly reduce CO ₂ emissions.
Focus	Revolutionize conventional cement production methods to align with sustainability objectives.
Importance	Acknowledges the cement industry's significant role in global greenhouse gas emissions.
Technological Innovations	Encourage pioneering technologies such as new manufacturing processes and carbon capture integration.
Performance Enhancement	Ensure resulting cement meets industry standards and maintains functionality in construction.
Collaboration	Promote global collaboration among nations, researchers, academia, and industry stakeholders.
Long-Term Vision	Foster lasting, sustainable change in the cement industry towards a low-carbon, responsible sector.

of expertise to drive sustainable solutions. Ultimately, the Cement Challenge envisions a low-carbon cement industry that aligns with environmental goals, ensuring a lasting positive impact on the planet and contributing to a sustainable future.

3.3.4. Global cement and Concrete Association (GCCA) sustainability charter

The Global Cement and Concrete Association (GCCA) serves as a unified voice, representing cement companies on a global scale. An essential initiative undertaken by the GCCA is the establishment of a Sustainability Charter, a guiding document that embodies the industry's unwavering commitment to sustainability (Teske et al., 2022). This charter is a collective declaration of intent, signifying the cement industry's proactive stance in addressing pressing environmental challenges and working towards a more sustainable future.

Central to the Sustainability Charter are the commitments aimed at reducing the carbon footprint of the cement industry. The GCCA understands the substantial role the cement sector plays in global carbon emissions, primarily due to the energy-intensive nature of cement production (Uratani and Griffiths, 2023). Therefore, a primary focus of the charter is to emphasize the reduction of CO₂ emissions. This entails embracing cleaner and more efficient technologies and practices throughout the production cycle, thereby significantly mitigating the industry's environmental impact. A vital component of this commitment involves an increased utilization of alternative fuels and raw materials in cement production. The industry is actively exploring and implementing innovative methods to replace traditional fossil fuels with sustainable alternatives. This not only aligns with reducing CO₂ emissions but also contributes to resource conservation and minimizing the industry's dependence on finite resources.

Improving energy efficiency is another critical aspect addressed by the GCCA's Sustainability Charter. Cement production is highly energy-intensive, and enhancing efficiency is crucial for reducing overall energy consumption and subsequently lowering the associated carbon emissions. The charter underscores the adoption of state-of-the-art technologies and practices that optimise energy usage and reduce the environmental footprint of the cement industry (Seku and Somani, 2014; Mishra et al., 2022). Furthermore, the Sustainability Charter places a strong emphasis on promoting circular economy practices within cement production. Circular economy principles involve minimizing waste, reusing materials, and recycling wherever possible. By incorporating circular economy practices, the cement industry aims to reduce its demand for raw materials, decrease waste generation, and contribute to a more sustainable and resource-efficient production process.

The GCCA displays a commendable proactive approach to sustainability through its Sustainability Charter, embodying a collective industry commitment. The focus on reducing the carbon footprint and energy consumption is critical, given the cement industry's significant

contribution to global emissions and energy use. However, a critical analysis warrants consideration of actual implementation and enforcement mechanisms. The effectiveness of cleaner technologies, increased use of alternative fuels, and circular economy practices should be rigorously monitored. Furthermore, addressing the socio-economic impacts of transitioning to sustainable practices and ensuring inclusivity across all stakeholders remains essential for a truly sustainable and impactful transformation within the industry.

Table 3 provides a concise summary of the key areas of focus within the GCCA's Sustainability Charter, emphasizing their commitment to sustainability, carbon footprint reduction, energy efficiency, and circular economy practices in the cement industry. The table distils essential aspects of the Global Cement and Concrete Association's (GCCA) Sustainability Charter, a visionary framework embodying the cement industry's unwavering dedication to sustainability. It delineates pivotal commitments directed at reducing the carbon footprint, focusing on cleaner technologies, embracing alternative fuels and raw materials, optimizing energy efficiency, and promoting circular economy practices. The charter underscores a proactive stance, recognizing the cement industry's significant role in global carbon emissions and prioritizing transformative measures to mitigate environmental impact. By encapsulating these commitments, the table encapsulates the GCCA's dedication to shaping a more sustainable and environmentally responsible future for the industry.

3.3.5. LEILAC (Low Emissions Intensity Lime and Cement)

LEILAC, which stands for Low Emissions Intensity Lime and Cement, is a pioneering and innovative project that seeks to revolutionize the cement and lime production industries by showcasing advanced carbon capture technology (Guo et al., 2024). The primary objective of this ground-breaking initiative is to address one of the most pressing challenges in the fight against climate change - reducing CO₂ emissions associated with cement and lime production.

Cement and lime production are notorious for their significant contribution to global greenhouse gas emissions. The process involves the calcination of limestone, releasing CO₂ as a by-product. This is a fundamental aspect of traditional cement and lime production, making it a major challenge to reduce emissions without compromising the core manufacturing processes. The urgency to find a solution to this issue cannot be overstated, given the critical role of these industries in global infrastructure development. The LEILAC project is designed to specifically target this carbon emissions challenge within the cement and lime production processes (Leeson et al., 2017; Benhelal et al., 2021). What makes LEILAC unique is its ability to capture CO₂ emissions directly from the production process without imposing substantial economic burdens. This sets it apart as a promising and cost-effective approach to reducing emissions within these industries.

The project utilises a novel technology that achieves carbon capture by operating on the principle of calcium looping. Calcium looping is a process that involves the cyclic reaction of calcium oxide (CaO) to capture CO₂ during the calcination of limestone. The captured CO₂ can then be separated, allowing for sequestration or utilization in other

Table 3
Key aspects of GCCA's sustainability charter.

Aspect	GCCA's Sustainability Charter
Objective	Cement industry's commitment to sustainability, focusing on reducing the carbon footprint.
Carbon Footprint Reduction	Embrace cleaner technologies, increase use of alternative fuels, and optimise raw material usage.
Alternative Fuels and Raw Materials	Explore and implement sustainable alternatives to fossil fuels and traditional raw materials.
Energy Efficiency	Adopt state-of-the-art technologies to optimise energy usage and reduce overall consumption.
Circular Economy Practices	Minimise waste, reuse materials, and recycle to reduce the demand for raw materials and waste.

applications. By demonstrating the efficacy of this technology, the LEILAC project paves the way for a more sustainable future for the cement and lime industries. The successful implementation of this carbon capture technology on an industrial scale would signify a significant breakthrough. It would provide the cement and lime industries with a feasible and practical pathway to decarbonize, aligning with global climate goals. Moreover, by showcasing a technology that does not impose substantial costs, LEILAC addresses a common concern associated with carbon capture initiatives. Cost-effectiveness is a crucial factor in the successful adoption of any emissions reduction technology, and the LEILAC project's ability to achieve this is a promising sign for the wider adoption of similar technologies in the future.

3.3.6. World Business Council for Sustainable Development (WBCSD) cement sustainability initiative (CSI)

The Cement Sustainability Initiative (CSI), led by the World Business Council for Sustainable Development (WBCSD), plays a vital role in propelling sustainability within the global cement industry (Patil and Sawant, 2014; Chatterjee and Sui, 2019). The initiative operates through collaboration with major cement companies worldwide, uniting their efforts to drive meaningful and impactful changes in the industry. One of the primary and overarching goals of the CSI is to significantly reduce carbon emissions associated with cement production. Carbon emissions from the cement industry are a major contributor to global greenhouse gas levels. By collaborating and leveraging the collective expertise and resources of member companies, the initiative aims to develop and implement strategies to cut down these emissions. This could include adopting low-carbon technologies, optimizing production processes, and enhancing energy efficiency.

Improving energy efficiency is another critical focus area of the CSI (Klee, 2004; Cook and Ponsard, 2011; Busch et al., 2017). Cement production is energy-intensive, and enhancing efficiency directly translates to reduced energy consumption and, consequently, lower greenhouse gas emissions. By sharing best practices and fostering innovation, the initiative drives the adoption of technologies and processes that make cement manufacturing more energy-efficient. Moreover, the CSI places a strong emphasis on promoting sustainable supply chains within the cement industry. This involves considering the entire lifecycle of cement, from raw material extraction to product disposal. The initiative advocates for responsible sourcing of raw materials, ethical and sustainable labour practices, and environmentally conscious production processes throughout the supply chain.

In line with sustainable practices, the CSI also focuses on effective land and biodiversity management. Cement production often involves land use, and it's imperative to ensure that this land use is responsible and sustainable, taking into account the conservation of biodiversity and ecosystems. The initiative advocates for land reclamation, habitat restoration, and responsible land-use planning to minimise the environmental footprint of the cement industry. Furthermore, the CSI serves as a platform for knowledge sharing and collaboration. Member companies collaborate on research and development projects, share best practices, and engage in dialogues with stakeholders across the spectrum, including governments, NGOs, and local communities. This collective effort strengthens the industry's ability to address sustainability challenges effectively.

3.3.7. IEA technology roadmap: Low-carbon transition in the cement industry

The International Energy Agency (IEA), a pivotal player in the global shift towards sustainable energy, has identified a significant challenge within the cement industry - its substantial carbon emissions (Jacoby, 2009; Van de Graaf, 2012; Heubaum and Biermann, 2015). Cement, a vital material in modern construction, is a major emitter of CO₂ during its production. Addressing this concern, the IEA has meticulously crafted a technology roadmap. This roadmap is more than a plan; it is a visionary document that charts the path to substantial reductions in CO₂

emissions from cement production by 2050.

At its core, this roadmap advocates for a fundamental transformation in the way cement is produced. It emphasizes the imperative of embracing innovative technologies. These could range from reimagining the very design of kilns to pioneering new methodologies for clinker production (Xu et al., 2014; Zhi and An, 2023). Innovations play a pivotal role in this roadmap, acting as catalysts for emission reductions. Energy efficiency emerges as another central focus. The roadmap calls for the optimisation of energy usage across the cement production process. By upgrading equipment, improving heat recovery systems, and implementing cutting-edge control mechanisms, the industry can drastically reduce its overall energy demand and, in turn, lower CO₂ emissions. Additionally, the roadmap underscores the importance of shifting towards alternative materials and fuels. This implies incorporating waste materials into the production process or utilizing renewable energy sources like biomass to replace fossil fuels. This shift aligns with sustainability goals, promoting a circular economy where waste is repurposed.

Notably, the roadmap identifies Carbon Capture and Storage (CCS) as a game-changer. CCS involves capturing CO₂ emissions from the cement production process and either storing them underground or finding productive uses for them (Salas et al., 2016; Cormos and Cormos, 2017; Fennell et al., 2021). This step can prevent a substantial portion of carbon emissions from entering the atmosphere. However, the IEA acknowledges that achieving these emissions reductions necessitates collaboration and commitment. Governments, industry players, technology developers, and research institutions must come together to drive this transformation. Moreover, supportive policy frameworks, financial incentives, and global cooperation are vital for the successful deployment of these strategies. Essentially, the IEA roadmap serves as a visionary blueprint, extending beyond the cement sector to influence the wider global sustainability agenda. It imagines a future where cement, a fundamental building block of our infrastructure, adopts innovation and sustainability, markedly reducing its carbon footprint. This, in turn, aids in advancing global climate goals, guiding us toward a more sustainable future.

Table 4 provides a succinct overview of the IEA's Technology Roadmap, focusing on the essential aspects and strategies needed to achieve substantial reductions in CO₂ emissions from cement production by 2050. The table encapsulates the critical strategies outlined in the International Energy Agency's (IEA) Technology Roadmap for the cement industry's carbon emissions reduction. This visionary roadmap aims to substantially lower CO₂ emissions from cement production by

Table 4

Key strategies in IEA's technology roadmap for carbon emissions reduction in cement industry.

Aspect	IEA Technology Roadmap for Cement Industry
Objective	Substantial reduction in CO ₂ emissions from cement production by 2050.
Focus Areas	Innovative technologies, energy efficiency, alternative materials, fuels, and Carbon Capture and Storage (CCS).
Innovative Technologies	Reimagine kiln design, pioneer new clinker production methodologies for emission reduction.
Energy Efficiency	Optimise energy usage through upgraded equipment, improved heat recovery, and advanced control mechanisms.
Alternative Materials and Fuels	Incorporate waste materials, use renewable energy sources like biomass to replace fossil fuels.
Carbon Capture and Storage (CCS)	Capture and store CO ₂ emissions from cement production, preventing a substantial portion from entering the atmosphere.
Collaboration and Commitment	Collaboration of governments, industry, technology developers, and research institutions for successful implementation.
Supportive Measures	Supportive policy frameworks, financial incentives, and global cooperation for effective deployment of strategies.

2050. It emphasizes innovation through advanced technologies, including kiln redesign and novel clinker production methods. Energy efficiency optimisation, incorporation of alternative materials and fuels, and the pivotal role of Carbon Capture and Storage (CCS) are highlighted. Collaboration across stakeholders, including governments, industry, and research institutions, is essential for successful implementation, supported by policy frameworks and financial incentives. This table provides a concise snapshot of the roadmap's key focus areas, promoting a sustainable and lower-emission future for the cement industry.

3.3.8. Government regulations and National policies

Table 5 provides an overview of the key strategies and policies adopted by governments to mitigate carbon emissions in the cement sector, showcasing the comprehensive approach taken to drive sustainability and environmental responsibility in the industry. The table encapsulates crucial strategies and policies aimed at reducing carbon emissions in the cement industry. Emission Reduction Targets set by governments drive innovation and promote the transition to low-carbon technologies. Carbon Pricing Mechanisms, such as taxes or cap-and-trade systems, provide economic incentives for emission reduction. Financial Incentives in the form of grants or tax credits encourage investment in sustainable technologies. Energy Efficiency Standards push for optimised energy usage, aiding cost savings and emission reduction. Collaborative Partnerships and Research and Development Investments foster a comprehensive approach, ensuring a sustainable and innovative pathway to significantly curbing carbon emissions in cement production.

Table 5

Key strategies and policies adopted by governments to mitigate carbon emissions in the cement sector.

Strategy/Policy	Description
Emission Reduction Targets	Governments set specific and measurable targets for cement companies to reduce their carbon emissions. These targets encourage the industry to innovate and transition towards low-carbon technologies, contributing to the reduction of overall emissions.
Carbon Pricing Mechanisms	Governments implement carbon pricing mechanisms such as carbon taxes or cap-and-trade systems. Carbon pricing puts a price on carbon emissions, providing economic incentives for cement companies to reduce emissions and invest in cleaner technologies, thus mitigating their carbon footprint.
Financial Incentives	Governments offer financial incentives like grants, subsidies, or tax credits to encourage cement companies to invest in low-carbon technologies. These incentives alleviate financial burdens and promote the adoption of sustainable practices, accelerating the reduction of carbon emissions in the cement sector.
Energy Efficiency Standards	Governments enforce energy efficiency standards for cement plants, requiring manufacturers to optimise energy usage and reduce waste. These standards drive cost savings, lower energy consumption per unit of output, and ultimately contribute to reduced carbon emissions from the cement industry.
Collaborative Partnerships	Collaborations between governments, industry stakeholders, and research institutions are fostered. Public-private partnerships and research collaborations enable the development of effective policies and strategies, ensuring a comprehensive approach to reducing carbon emissions in the cement sector through combined expertise and resources.
Research and Development Investments	Governments invest in research and development initiatives specifically targeting low-carbon technologies for the cement industry. These investments encourage innovation, fostering the creation of breakthrough technologies that can revolutionize cement production, ultimately leading to significant reductions in carbon emissions within the sector.

4. Low-CO₂ emission technologies in cement production

Low-CO₂ cement production technologies revolve around minimizing CO₂ emissions in the cement manufacturing process. These innovative approaches aim to transform a traditionally carbon-intensive industry into a more environmentally sustainable one. The methods involve using alternative raw materials and fuels, incorporating carbon capture, utilization, and storage (CCUS) techniques, as well as exploring carbon offsetting and sustainable practices. Additionally, advancements such as alkali-activated cements and the utilization of alternative raw materials play significant roles in reducing the overall carbon footprint of cement production. These technologies present a promising avenue to reconcile cement production with environmental stewardship and climate change mitigation effort.

4.1. Carbon capture, utilization, and storage (CCUS) in the cement industry

Carbon Capture, Utilization, and Storage (CCUS) stand as a vital approach in the cement industry, offering a multifaceted strategy to combat the substantial CO₂ emissions associated with cement production. In the initial phase, CCUS involves the capture of CO₂ emissions at the source before they are released into the atmosphere. This is a critical step in the cement production process, which is known for its substantial emissions, particularly due to the calcination process. Once captured, the next facet of CCUS is utilization, wherein the captured CO₂ is converted into valuable products. In the context of the cement industry, this involves mineralising the CO₂ to create materials like aggregates or supplementary cementitious materials (Galvez-Martos et al., 2021; Coffetti et al., 2022). These products can then be employed in concrete production, effectively integrating the captured CO₂ into the construction process, and thus, adding value to an otherwise harmful greenhouse gas. Furthermore, the final aspect of CCUS involves storage, where the captured CO₂ is securely stored underground to prevent its release into the atmosphere. Geological formations like deep saline aquifers, depleted oil and gas reservoirs, or un-mineable coal seams are common sites for this storage (Gale, 2004; Buttinelli et al., 2011; Jafari et al., 2017; Zhang and Huisingsh, 2017). This ensures that the CO₂ remains sequestered, contributing to long-term efforts to mitigate climate change.

The advantages of CCUS in the cement industry are significant. It promises a substantial reduction in emissions, aligning with global sustainability goals. The potential to convert CO₂ from a pollutant to a valuable resource represents a key advantage. By utilizing CO₂ to create construction materials, the industry can move towards a circular economy, reducing waste and optimizing resource usage. Moreover, integrating CO₂ into cementitious products enhances the overall sustainability of the industry. However, there are challenges to be addressed. The maturation of CCUS technologies is imperative to enhance their efficiency and reduce costs, making them more accessible for widespread adoption. Establishing the necessary infrastructure for capturing, transporting, and storing CO₂ presents a logistical and financial challenge. Additionally, public acceptance and understanding of CO₂ storage are crucial, necessitating educational efforts and transparent communication.

4.2. Alternative raw materials and alternative fuels

Table 6 provides an overview of various alternative raw materials and fuels commonly utilised in the cement industry, outlining their descriptions and the benefits they offer in terms of reducing carbon emissions, minimizing waste, and contributing to a more sustainable production process. The table succinctly outlines various alternative raw materials and fuels utilised in cement production, presenting their respective descriptions and benefits. Alternative raw materials like Fly Ash and Slag are by-products, contributing to reduced energy

Table 6
Alternative raw materials and alternative fuels in cement production.

Type	Description	Benefits
Alternative Raw Materials		
Fly Ash	By-product of coal combustion.	Reduces carbon emissions and energy usage in production.
Slag	By-product of iron and steel production.	Lowers energy consumption during clinkerization.
Natural Pozzolans	Naturally occurring pozzolanic materials.	Partial substitution for clinker with reduced emissions.
Calcined Clays	Clays heated at lower temperatures.	Substitutes clinker, decreasing CO ₂ emissions.
Rice Husk Ash (RHA)	Ash obtained from rice husks.	Enhances concrete properties and uses agricultural waste.
Recycled Concrete Aggregate (RCA)	Crushed waste concrete used as aggregate.	Reduces the need for new aggregate production.
Alternative Fuels		
Biomass	Organic materials like wood or agricultural waste.	Renewable source, reduces reliance on fossil fuels.
Waste-derived Fuels	Derived from various waste materials.	Addresses waste management and provides an energy source.
Tires	Scrap tires processed for use as fuel.	Diverts tire waste from landfills and replaces fossil fuels.
Waste Oils	Recycled waste oils used as fuel.	Provides an alternative to fossil fuel usage.
Non-recyclable Plastics	Non-recyclable plastics converted to plastic-derived fuel (PDF).	Addresses plastic waste and offers an energy source.

consumption and lower carbon emissions during cement production. Natural Pozzolans and Calcined Clays offer environmentally friendly substitutions for clinker, further minimizing CO₂ emissions (Huntzinger and Eatmon, 2009; Imbabi et al., 2012; Scrivener et al., 2018). On the other hand, alternative fuels such as Biomass and Waste-derived Fuels are renewable sources that decrease reliance on fossil fuels and tackle waste management challenges (Georgiopoulou and Lyberatos, 2018; Hossain et al., 2019; Vasiliu et al., 2023). These alternatives collectively contribute to sustainable and greener cement manufacturing while effectively addressing environmental concerns and promoting circular economy principles.

Incorporating alternative raw materials and fuels into cement production mitigates the environmental impact of the industry. It decreases reliance on traditional resources, lowers energy consumption, reduces CO₂ emissions, and promotes circular economy practices by utilizing waste materials. Furthermore, it aligns with the industry's sustainability goals, contributing to a more environmentally responsible cement manufacturing process. However, appropriate processing, quality control, and regulatory compliance are essential to ensure the successful integration of these alternatives into cement production.

4.3. Carbon offsetting and sustainable practices

Carbon offsetting and sustainable practices in cement production are pivotal strategies that drive the industry towards a more environmentally responsible approach. These initiatives are crucial in mitigating the environmental impact, particularly the CO₂ emissions, associated with cement manufacturing. Carbon offsetting involves compensating for the unavoidable CO₂ emissions produced during cement manufacturing (Xi et al., 2016; Power et al., 2017; Ostovari et al., 2021). This is achieved by investing in projects that either reduce or remove an equivalent amount of greenhouse gases from the atmosphere. It enables the industry to counterbalance its carbon footprint through various certified projects such as reforestation, renewable energy ventures, and energy efficiency initiatives.

Sustainable practices within cement production encompass a

spectrum of approaches that prioritize responsible resource management and environmental stewardship. One fundamental strategy involves integrating alternative raw materials and fuels into the manufacturing process. By incorporating materials like fly ash, slag, or utilizing biomass as a fuel source, the industry reduces its reliance on traditional resources, thus minimizing its environmental impact.

Efficiency plays a critical role in sustainability. Waste heat recovery systems, for instance, allow the industry to capture and utilise heat from cement kilns, translating into energy efficiency and reduced overall energy consumption. Moreover, optimizing cementitious materials usage and employing efficient kiln technologies significantly enhance sustainability by curbing waste and reducing energy consumption. Another pivotal sustainable practice involves responsible sourcing and supply chain management. By ensuring that raw materials are ethically sourced and supply chains adhere to sustainable practices, the industry minimises its ecological footprint and upholds social responsibility.

5. Innovative approaches and emerging technologies

Innovative approaches and emerging technologies in cement production are pivotal in revolutionizing the industry towards sustainability. Alkali-activated cements, utilizing alternative raw materials, and biomass co-processing are at the forefront. Alkali-activated cements significantly reduce CO₂ emissions by operating at lower temperatures. Alternative raw materials like fly ash and slag mitigate the environmental impact by substituting clinker. Biomass co-processing not only offers an alternative fuel source but also manages waste. Moreover, electrification, carbon capture and utilization (CCU), and novel production techniques promise a more eco-friendly and efficient future, essential for achieving a sustainable cement sector.

5.1. Alkali-activated cements

Alkali-activated cements represent a significant departure from conventional cement production methods. Unlike the widely used Portland cement, which relies heavily on limestone and high-temperature calcination, alkali-activated cements harness the potential of aluminosilicate materials. These materials, often industrial waste products like fly ash, slag, or natural clays, contain substantial amounts of reactive components such as silica and alumina. The process of alkali activation involves blending these aluminosilicate materials with alkali activators, usually a combination of sodium or potassium hydroxide and silicate solutions (Ryu et al., 2013; Kashani et al., 2014; Da Silva Rocha et al., 2018). This interaction initiates a chemical reaction that ultimately forms a stable, cementitious binder. This binder can then be employed for a multitude of construction applications. Fig. 4 shows the production of alkali-activated concrete by a two-part mix.

One of the standout features of alkali-activated cements is the significantly reduced energy requirements during production. The traditional production of Portland cement necessitates high-temperature processes, making it energy-intensive. In contrast, alkali-activated cements operate at notably lower temperatures, leading to substantial energy savings. This energy efficiency, coupled with the ability to use waste materials as primary components, contributes to a noteworthy reduction in the carbon footprint of the cement industry. Alkali-activated cements offer commendable mechanical properties, including high durability and strength. These properties make them suitable for a wide array of construction applications, from residential buildings to major infrastructure projects. Moreover, the versatility of the alkali activation process allows for tailoring formulations to meet specific requirements, enhancing adaptability and applicability.

In essence, alkali-activated cements showcase the potential to revolutionize the construction industry. Their capacity to utilise industrial waste not only addresses waste management but also alleviates the strain on natural resources. As ongoing research continues to refine the alkali activation process and explore new materials, these innovative

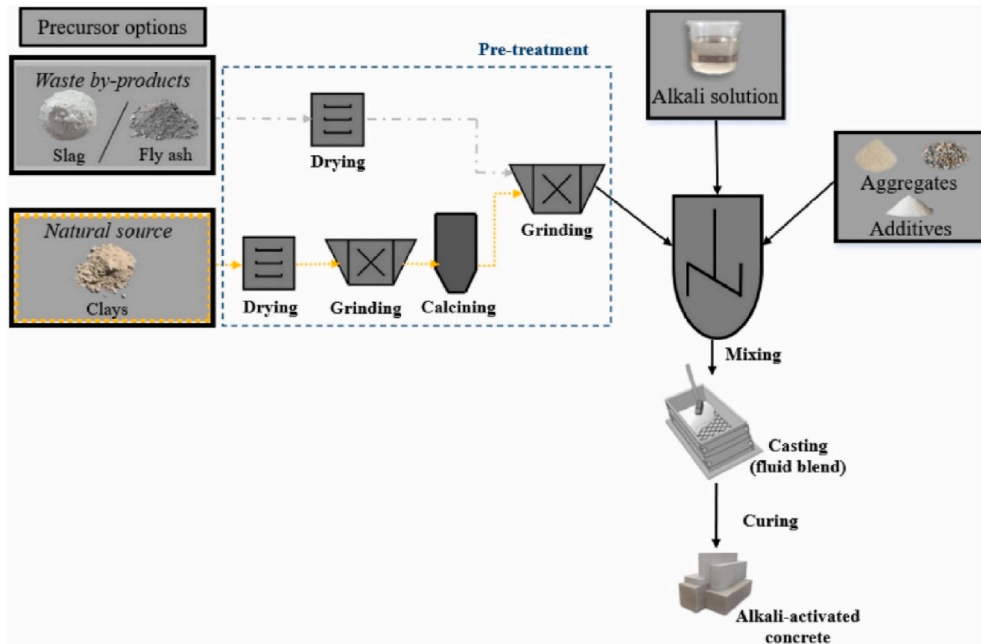

Fig. 4. Production of alkali-activated concrete by a two-part mix (Segura et al., 2023).

cements are poised to become a central component in sustainable and eco-friendly construction practices, offering a path toward a greener and more efficient future.

5.2. Calcium looping process

The Calcium Looping Process (CLP) presents an innovative approach to tackle CO₂ emissions in the cement production sector. At its core is the reversible carbonation-calcination reaction involving calcium oxide (CaO), commonly known as lime (Fig. 5). In the carbonation phase, flue gas enriched with CO₂ resulting from cement production is brought into contact with calcium oxide. This interaction triggers a chemical reaction where CaO reacts with CO₂ to form calcium carbonate (CaCO₃). This process effectively captures the CO₂ from the flue gas, preventing it from

being released into the atmosphere.

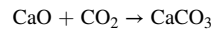

The captured CO₂, now in the form of calcium carbonate, is then subjected to the calcination phase. In this stage, the calcium carbonate is heated to release pure CO₂ and regenerate calcium oxide (CaO), which can be used in subsequent carbonation cycles. The reaction is as follows:

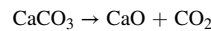

The major advantage of this process lies in the reusability of calcium oxide. The captured CO₂ is released during calcination, regenerating CaO, which can be used again in the carbonation stage. This cyclic process allows for the capture and release of CO₂ in a sustainable and efficient manner. Importantly, the CO₂ captured through this process is

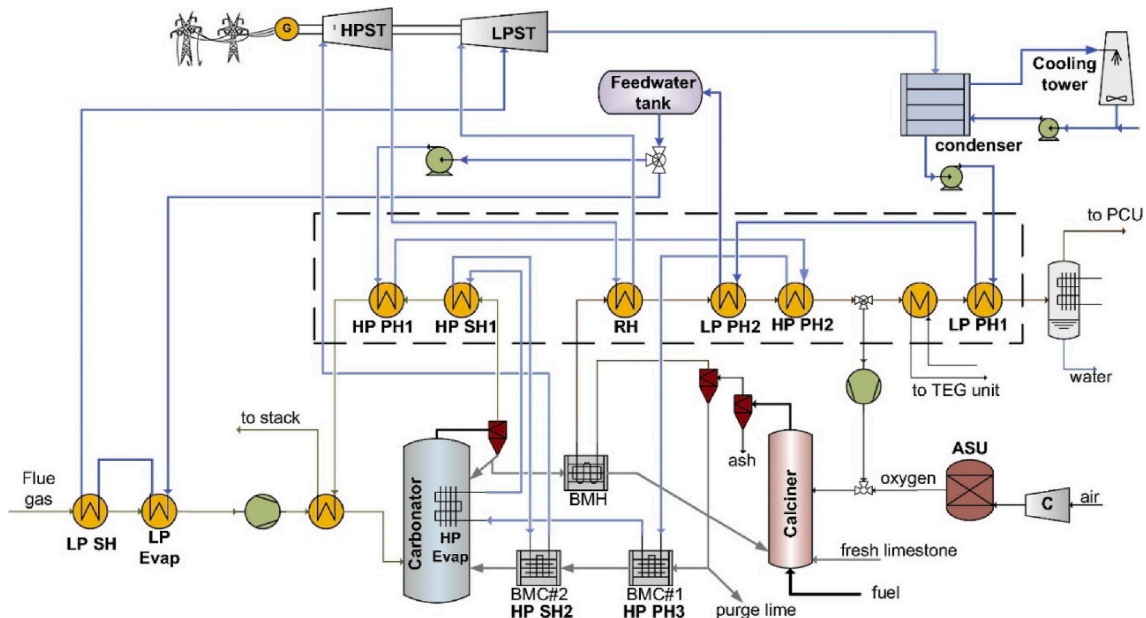

Fig. 5. Process configuration of the calcium looping unit (Atsonios et al., 2015).

typically of high purity, making it suitable for various applications, including storage or utilization without the need for additional purification steps. The integration of the Calcium Looping Process in cement production can be seen as a promising step towards reducing carbon emissions. Despite certain challenges, including the need to optimise the efficiency of the reaction and manage the cyclic performance, ongoing research and development efforts are focused on overcoming these hurdles to ensure the effective implementation and commercial viability of this technology.

The study by [Telesca et al. \(2014\)](#) significantly contributes to the symbiosis between carbon capture and cement production. By showcasing the potential utilization of spent limestone sorbent from the calcium looping cycle as a raw material for the cement industry, the paper proposes an innovative approach. This symbiotic relationship between carbon capture and cement production could be a pivotal strategy for reducing the overall environmental footprint of the cement sector. It effectively demonstrates how waste from one process can be repurposed as a valuable resource for another, fostering sustainability and resource efficiency within the industry. In the research conducted by [De Lena et al. \(2019\)](#), a techno-economic analysis of calcium looping processes for low CO₂ emission cement plants is presented. Their comprehensive study delves into the economic viability of implementing CLP. The emphasis on assessing both technological feasibility and economic sustainability underscores a critical aspect. Understanding the economic intricacies of the Calcium Looping Process is paramount for its widespread adoption within the cement industry. This economic evaluation provides essential insights for investors, policymakers, and stakeholders, facilitating informed decision-making.

The analysis by [Diego et al. \(2016\)](#) concentrating on a double calcium loop process configuration for CO₂ capture in cement plants is particularly noteworthy. The study sheds light on the complexities associated with different configurations of the Calcium Looping Process. By providing insights into engineering challenges and considerations, this research is instrumental in guiding the optimal configuration and implementation of CLP. Understanding the nuances of configuration is crucial in devising an efficient and effective carbon capture strategy for cement plants. [Schakel et al. \(2018\)](#) investigated the influence of fuel selection on the environmental performance of post-combustion calcium looping applied to a cement plant. This research underscores the critical relationship between the choice of fuel and the efficiency of the CLP. Understanding how various fuels impact the environmental benefits of the process is essential for optimizing its efficacy. It provides valuable insights into how the choice of fuel can be leveraged to maximise environmental advantages in the context of carbon capture in cement plants.

[Erans et al. \(2018\)](#) conducted pilot testing of enhanced sorbents for calcium looping with cement production. Their work represents a crucial step in validating the viability and efficiency of the Calcium Looping Process at a larger scale. This experimental testing contributes valuable data for the practical implementation of the technology. It provides real-world validation of the theoretical concepts, helping bridge the gap between theory and practical application. The experimental investigations by [Hornberger et al. \(2020, 2021\)](#) on the calcination and carbonation reactors in tail-end calcium looping configurations for CO₂ capture from cement plants offer pivotal insights. These studies provide a deeper understanding of the reactors' performance and optimisation. By advancing our knowledge of the Calcium Looping Process at a reactor level, they enable more efficient and effective implementation, bringing us closer to practical large-scale application of CLP in the cement industry.

The proposed one-dimensional model of an entrained-flow carbonator for CO₂ capture in cement kilns by [Spinelli et al. \(2018\)](#) represents a significant contribution. Modelling efforts like this are vital in predicting and optimizing the behaviour of the Calcium Looping Process under varying conditions. This predictive modelling facilitates a deeper understanding of the process dynamics, aiding in the optimal design and

operation of the carbonation reactor. It opens avenues for predictive control and optimisation, key aspects for the successful integration of CLP in cement production.

The referenced papers collectively present a multidimensional exploration of the Calcium Looping Process in cement production. Spanning from techno-economic evaluations to experimental investigations, these studies provide a comprehensive understanding of the potential and challenges associated with implementing CLP. The insights gained from these studies are invaluable for researchers, policymakers, and practitioners aiming to mitigate carbon emissions from the cement industry, fostering sustainable practices and aiding in the global battle against climate change.

5.3. Electrification and renewable energy integration

The integration of electrification and renewable energy sources marks a paradigm shift in the cement production landscape, embodying a commitment to sustainability and environmental stewardship. Electrification involves transitioning from conventional, fossil fuel-dependent machinery to the utilization of electric-powered equipment throughout the cement manufacturing process. Electric kilns, a cornerstone of this shift, epitomize this transition. These kilns employ electrical heating elements instead of traditional fossil fuels, leading to reduced emissions and heightened operational efficiency. Additionally, various grinding and mixing processes vital to cement production can now be powered by electricity, offering a cleaner and more efficient alternative to fuel-powered machinery.

Complementing this electrification effort is the integration of renewable energy sources. Solar, wind, and hydropower sources are harnessed to power cement plants. Solar panels installed on-site or sourced from solar farms, wind turbines, and hydropower generators contribute a substantial share of the energy required for the production process. This integration significantly curtails the carbon footprint traditionally associated with reliance on non-renewable energy sources. Further enhancing sustainability are renewable thermal energy sources like biomass and biogas. These resources are employed to substitute fossil fuels in cement kilns, thus minimizing environmental impact and fostering a circular economy by reusing waste materials.

Efficient energy storage solutions, such as advanced batteries, play a pivotal role in ensuring a stable and reliable power supply, especially when relying on intermittent renewable energy sources. Energy storage systems store excess energy generated during peak production periods for later use, mitigating the intermittent nature of renewable energy. This transformation not only significantly reduces carbon emissions but also optimises resource utilization and lowers operational costs. Moreover, it positions the cement industry as a responsible stakeholder in sustainable practices, in line with global environmental objectives. By adopting electrification and integrating renewable energy sources, the cement industry embraces a more sustainable and eco-conscious future, acknowledging its role in addressing climate change and promoting a greener world.

The integration of electrification and renewable energy sources in the cement production industry was a critical step towards reducing its substantial carbon footprint and environmental impact. The references cited presented a variety of innovative strategies and technologies that highlighted the potential for clean energy integration in this traditionally carbon-intensive sector. [Zhang et al.'s \(2019\)](#) framework for integrated energy optimisation demonstrated the significance of efficient energy utilization in cement plants. Optimizing energy consumption was a fundamental aspect of sustainability, and leveraging renewable sources for energy could significantly contribute to this optimisation. However, the paper could have delved deeper into the specific challenges and barriers encountered during the implementation of this framework in an industrial setting. [Al-Ghussain et al. \(2018\)](#) emphasized the importance of hybrid PV-wind systems, showcasing their potential through a case study. While the study effectively highlighted the viability of combining

renewable sources, further discussion on the economic aspects, scalability, and challenges in implementing such hybrid systems on a broader scale within the cement industry would have enhanced the paper's depth.

Tregambi et al. (2018) explored solar-driven lime production, providing a unique perspective on utilizing solar energy directly in the cement manufacturing process. However, the paper might have benefited from a comparative analysis with other renewable energy integration approaches to highlight the advantages and limitations of solar-driven systems in this context. Mikulčić et al. (2016) stressed the importance of alternative energy sources in cleaner cement manufacturing. This aligned with the broader goal of sustainability; however, a deeper exploration of the economic and technological challenges associated with the large-scale adoption of alternative energy sources in the cement industry would have been warranted.

Kusuma et al.'s (2022) review on the sustainable transition toward a biomass-based cement industry was particularly relevant given the growing interest in biomass as a clean energy source. The review offered valuable insights, yet further discussion on the scalability, resource availability, and potential environmental implications of relying on biomass was essential for a comprehensive understanding. Ferrario et al. (2023) proposed a solar-driven calcium looping system, an innovative approach with the potential to revolutionize carbon capture in cement plants. However, the paper could have further explored the scalability and economic viability of implementing such a system in existing cement plants, considering the initial investment and operational costs involved.

Jamali and Noorpoor (2019) presented an optimised solar-based multi-generation system for waste heat recovery, highlighting the multifaceted benefits of renewable energy integration. However, a discussion on potential integration challenges, technical constraints, and adaptability to various cement plant settings would have enhanced the practicality of the proposed system. Bolt et al. (2023) proposed a multigenerational energy system with hydrogen production, suggesting a promising avenue for clean energy in cement plants. However, a deeper analysis of the feasibility, hydrogen storage, and the potential impacts of hydrogen utilization on the cement production process was necessary.

The integration of electrification and renewable energy in the cement industry held immense promise in reducing its environmental impact. The studies discussed provided valuable insights, but a more comprehensive exploration of economic feasibility, scalability, technical challenges, and holistic environmental implications was essential for the effective implementation of these strategies on a broader scale. Further research and interdisciplinary collaboration were necessary to address the complexity of transitioning the cement industry to a sustainable and electrified future.

5.4. Biomimicry and bio-inspired cementitious materials

Biomimicry and bio-inspired cementitious materials are an emerging field revolutionizing the way we produce construction materials by taking cues from nature's designs and processes. Drawing inspiration from natural structures, this approach aims to create cement and concrete that mimic the resilience, adaptability, and sustainability seen in various organisms and ecosystems. In the realm of biomimicry, the structural designs found in nature, like the hierarchical patterns in bones or shells, are emulated to optimise the structure of cementitious materials. This imitation can enhance the strength and durability of the resulting construction materials. Moreover, the ability of some organisms to repair themselves is mimicked to create self-healing cementitious materials. This innovation holds the potential to significantly prolong the lifespan of structures by autonomously repairing cracks and damages.

Bio-inspired cementitious materials encompass a range of fascinating approaches. For instance, bacterial cementation involves using bacteria

that precipitate calcium carbonate to harden sand particles, creating a material akin to natural stone. Algae-based cement integrates algae or microalgae into cementitious mixtures, improving properties like compressive strength and reducing the carbon footprint by absorbing CO₂ during their growth. Additionally, cellulose nanocrystals derived from plant fibres can be incorporated into cementitious mixtures, enhancing mechanical properties and reducing the need for a large amount of cement. This integration of biomimicry and bio-inspired principles into cement production is steering the industry towards sustainability. Not only does this approach result in the creation of more eco-friendly materials, but it also demonstrates resource efficiency by utilizing minimal materials to achieve optimal structural and functional properties. Moreover, it contributes to reducing the carbon footprint of the industry by integrating bio-based materials and processes that sequester or utilise CO₂.

The potential of biomimicry and bio-inspired cementitious materials is immense, promising a future where construction materials are not only strong and reliable but also environmentally conscious and sustainable. Collaborations and continued research in this field are expected to drive further innovation, leading to breakthroughs in cement production and, consequently, the construction industry as a whole. Biomimicry and bio-inspired cementitious materials were explored as an innovative approach in the construction material field, drawing inspiration from nature to enhance the properties and functionality of cement-based products. The critical discussion below was based on the provided references, each offering distinct insights into the application of biomimicry in cementitious materials.

Li et al. (2019) introduced a novel bio-inspired bone-mimic self-healing cement paste that capitalized on hydroxyapatite formation. This approach emulated the self-healing properties observed in bones, where hydroxyapatite contributed to the natural healing process. By integrating this biomimetic concept into cementitious materials, the research presented a potential solution for enhancing the durability and longevity of cement-based structures. This bio-inspired approach leveraged the innate healing mechanisms of living organisms to develop materials that could autonomously repair and regenerate, a promising stride towards sustainable and resilient construction materials.

Li et al. (2020) proposed a biomimetic design utilizing Murray's law to create a 3D vascular structure for self-healing in cementitious materials. This innovative design mimicked the vascular system in natural organisms, optimizing the distribution and flow of healing agents within the cement matrix. By mimicking nature's efficient transport networks, this bio-inspired approach aimed to enhance the self-healing capacity of cementitious materials, potentially mitigating damage and prolonging the service life of concrete structures. It emphasized the importance of bio-inspired designs not just at the material level but also in the structural and functional aspects, presenting a holistic biomimicry approach.

Liu et al. (2023) delved into the development of bio-inspired cement-based material by magnetically aligning graphene oxide nanosheets in cement paste. This approach drew inspiration from the structure of certain biological entities and applied magnetic alignment to enhance the material properties. By mimicking natural alignment processes found in biological systems, this research harnessed the potential of nanotechnology and biomimicry to optimise the mechanical and structural attributes of cementitious materials. The study showcased the integration of bio-inspired strategies with advanced technologies, hinting at the broad spectrum of possibilities when it came to enhancing construction materials.

The above references demonstrated the potential of biomimicry and bio-inspired approaches in revolutionizing the properties and performance of cementitious materials. These studies highlighted the versatility of biomimicry, ranging from incorporating natural healing mechanisms to mimicking vascular structures and leveraging nanotechnology for improved alignment. The biomimetic pathway not only brought sustainable solutions but also underscored the importance of interdisciplinary research, encouraging collaborations between

biologists, material scientists, and engineers. As biomimicry continued to evolve, it held the promise of shaping the future of sustainable construction practices by emulating the efficiency and resilience found in the natural world.

6. Economic and policy considerations for a net-zero carbon cement sector

Economic and policy considerations are crucial in steering the cement sector towards a net-zero carbon future. Economic viability of low-carbon technologies is central, ensuring that sustainable practices align with industry profitability. Cost analyses, investment incentives, and funding for research and development play key roles. Moreover, governmental policies, including carbon pricing and emission regulations, shape the industry's trajectory. Incentives such as tax breaks for sustainable practices encourage adoption. Public-private partnerships and international collaborations further amplify the collective effort needed to achieve a net-zero carbon cement sector, emphasizing the significance of a conducive economic and policy framework in driving sustainable change.

6.1. Cost analysis and economic viability of Low-CO₂ technologies

Cost analysis and economic viability are paramount considerations when evaluating and implementing low-CO₂ technologies in the cement industry. These technologies aim to reduce carbon emissions, enhance sustainability, and align with global climate targets. However, their successful adoption hinges on being economically feasible and competitive with traditional, carbon-intensive methods.

The hypothetical Table 7 provides a brief overview of various low-CO₂ technologies, outlining their costs, potential savings, and the economic aspects involved. For a successful and sustainable shift towards low-CO₂ technologies in the cement sector, a comprehensive understanding of cost dynamics, economic incentives, and long-term implications is paramount. Striking the right balance between upfront investments and efficiency gains is key, but equally critical is policy support and foreseeing future prospects. Governments, through incentives and grants, significantly influence the economic viability of sustainable technologies. Additionally, long-term economic implications, like job creation and market growth, should be considered. Navigating these factors thoughtfully ensures the judicious adoption of low-CO₂ technologies, essential for a greener and economically sound cement industry. The cost analysis and economic viability of low-CO₂ technologies within the cement industry have been a critical area of research, aiming to strike a balance between environmental sustainability and economic feasibility. The discussion below is based on the provided references, each offering insights into the technical, economic, and environmental aspects of implementing low-CO₂ technologies in

cement plants.

Rolfe et al. (2018) conducted a technical and environmental study comparing calcium carbonate looping with oxy-fuel options for low CO₂ emission cement plants. The study emphasized the importance of considering not only the technical aspects but also the environmental implications and cost-effectiveness of implementing different carbon capture technologies. The findings shed light on the economic trade-offs involved in choosing a suitable low-CO₂ technology for the cement industry. Nwaoha et al. (2018) presented a techno-economic analysis of CO₂ capture using an AMP-PZ-MEA blend in a cement plant. The research focused on evaluating the economic viability of the capture process. Understanding the economic implications of utilizing specific capture blends is crucial for making informed decisions regarding the implementation of low-CO₂ technologies in cement plants. Cloete et al. (2020) performed an economic assessment of the swing adsorption reactor cluster for CO₂ capture from cement production. The economic evaluation provided valuable insights into the feasibility and cost-effectiveness of this particular capture approach. It highlighted the significance of economic assessments in determining the viability and scalability of carbon capture technologies in cement production.

Poudyal and Adhikari (2021) discussed environmental sustainability in the cement industry, emphasizing an integrated approach for green and economical cement production. The research highlighted that economic sustainability must be aligned with environmental sustainability to achieve a sustainable cement industry. This approach underscores the importance of integrating economic viability into the broader framework of sustainability in cement production. Magli et al. (2022) focused on the techno-economic optimisation and off-design analysis of CO₂ purification units for cement plants with oxyfuel-based CO₂ capture. The study delved into the optimisation of purification units, which is critical for both economic viability and the efficiency of the capture process. The research emphasized the need for optimizing various components of the capture process to achieve economic sustainability.

The discussed references collectively underscore the significance of incorporating economic considerations into the evaluation of low-CO₂ technologies for the cement industry. Economic viability and sustainability are interlinked, and it is imperative to consider the economic implications alongside the technical and environmental aspects. Balancing cost-effectiveness while striving for reduced carbon emissions is crucial for the successful adoption and widespread implementation of low-CO₂ technologies in the cement sector. These studies contribute to a comprehensive understanding of the economic dynamics and challenges associated with transitioning towards a more sustainable cement industry.

Table 7

Brief overview of various low-CO₂ technologies, outlining their costs, potential savings, and the economic aspects.

Low-CO ₂ Technology	Upfront Costs	Operational Costs	Potential Savings	Economic Incentives	Long-term Economic Impact
Carbon Capture and Storage (CCS)	High initial investment for infrastructure	Ongoing costs for capture and storage	Significant savings through reduced emissions penalties	Government grants, tax credits	Job creation, reduced healthcare costs due to reduced pollution
Alternative Raw Materials	Moderate initial costs for processing	Operational costs for collection and processing	Savings through reduced consumption of traditional raw materials	Government subsidies, waste utilization incentives	Sustainable resource management, reduced pressure on natural resources
Energy-Efficient Kilns	High initial costs for kiln modification	Lower energy costs in operations	Significant savings in energy consumption	Government grants, tax incentives	Reduced energy demand, cost savings for the industry
Biomass Co-processing	Moderate initial investment for co-processing equipment	Costs for biomass acquisition and processing	Savings through reduced fossil fuel usage	Government grants, renewable energy credits	Reduced carbon footprint, sustainable resource use
Waste Heat Recovery	Moderate initial investment for heat recovery systems	Operational costs for maintenance and integration	Savings through energy recovery	Tax incentives, energy efficiency grants	Improved energy efficiency, reduced energy costs

6.2. Incentives, regulations, and governmental policies driving Low-CO₂ emission strategies

Incentives, regulations, and governmental policies play a pivotal role in driving the adoption of low-CO₂ emission strategies within the cement industry. These mechanisms are essential for accelerating the transition towards sustainable practices and mitigating the environmental impact of cement production. Table 8 provides an overview of various incentives, regulations, and governmental policies that drive the adoption of low-CO₂ emission strategies in the cement industry, outlining their respective descriptions and impacts.

Di Filippo et al. (2019) discussed the impacts of policies aimed at reducing CO₂ emissions within the concrete supply chain. The study acknowledged the critical role of policies in shaping the industry's response to climate change. However, it emphasized that the effectiveness of these policies is contingent on their design and implementation. The discussion underscores that well-crafted policies, incentivizing and regulating low-CO₂ practices, are essential for inducing meaningful change across the cement industry's supply chain. Miller et al. (2021) presented a comprehensive strategy to achieve net-zero greenhouse gas emissions in the cement industry. Their research stressed the necessity of integrating mitigation strategies across the value chain. The discussion highlighted that effective policies should not only target specific stages of production but also encourage a holistic approach, considering raw materials, manufacturing processes, and transportation. This approach aligns with the notion that regulatory frameworks must be multifaceted and inclusive to drive substantial reductions in carbon emissions.

Ahmed et al. (2021) offered an overview of the Asian cement industry with a focus on environmental impacts, research methodologies, and mitigation measures. The paper recognized the diverse

Table 8
An overview of various incentives, regulations, and governmental policies.

Aspect	Description
Carbon Pricing	Governments impose a monetary cost on carbon emissions, encouraging industries to invest in low-CO ₂ technologies to minimise financial implications and align with sustainability goals.
Emission Standards and Regulations	Governments set strict limits on CO ₂ and pollutant emissions, compelling the cement industry to adopt low-CO ₂ technologies to comply with regulatory requirements and reduce their environmental impact.
Research and Development Grants	Governments allocate funds to support research and development in low-CO ₂ technologies, incentivizing cement manufacturers to innovate and invest in sustainable solutions for the production process.
Tax Incentives and Subsidies	Governments offer tax breaks, reduced tax rates, or subsidies on equipment purchases, encouraging cement companies to invest in low-CO ₂ technologies by reducing the financial burden and upfront costs.
Renewable Energy Support	Governments provide incentives and subsidies to promote the integration of renewable energy sources, incentivizing cement plants to shift to cleaner, sustainable energy options and reduce their carbon footprint.
Carbon Offset Programs	Industries can invest in carbon offset projects to compensate for their emissions, encouraging cement companies to engage in environmental initiatives like reforestation or renewable energy to offset their CO ₂ emissions.
Public-Private Partnerships (PPPs)	Collaboration between public and private sectors facilitates the development and implementation of low-CO ₂ strategies, encouraging knowledge sharing, funding, and effective policy formation for sustainability.
International Agreements and Commitments	Participating in global agreements like the Paris Agreement motivates governments to align policies with international emission reduction goals, compelling the cement industry to adopt low-CO ₂ technologies to meet these targets.

environmental challenges faced by the industry in the Asian context. It underscored that tailored policies are needed, considering the unique characteristics and challenges prevalent in the region. The discussion emphasized the importance of region-specific regulations and incentives to facilitate the adoption of low-CO₂ technologies in Asian cement plants.

The discussed references highlight the pivotal role of policies and regulations in steering the cement industry towards low-CO₂ emission strategies. These studies emphasize the need for well-designed policies that encompass the entire supply chain and consider regional contexts. Effective governmental incentives and regulations should incentivize research, encourage sustainable practices, and ensure a coordinated effort across stakeholders to successfully mitigate carbon emissions in the cement industry. Policymakers must tailor regulations to the specific needs and challenges of the industry, promoting a transition towards sustainable and low-CO₂ technologies.

6.3. Public and private sector collaboration for sustainable cement production

Public and private sector collaboration for sustainable cement production represents a powerful synergy aimed at mitigating the environmental impact of the cement industry while fostering economic growth. This collaboration encompasses various aspects, showcasing the collective determination to address sustainability challenges. Table 9 provides a structured overview of the key collaborative aspects driving sustainability in the cement industry.

The collaboration between the public and private sectors is pivotal for advancing sustainable cement production. Leveraging their respective strengths, resources, and expertise, these partnerships drive innovation, investment, and policy changes crucial for a sustainable and environmentally responsible cement industry. Public entities provide the regulatory framework, research support, and funding, while private companies contribute innovation, efficiency, and investment capacity. Together, they foster a symbiotic environment that accelerates the development and adoption of eco-friendly technologies, paving the way towards a greener and more sustainable future in cement production.

The collaboration between the public and private sectors in the pursuit of sustainable cement production was critically examined based on key insights and findings from various studies. The objective was to assess the role and impact of such collaboration in advancing

Table 9
Public and private sector collaboration for sustainable cement production.

Aspect	Description
Knowledge Exchange and Expertise Sharing	Exchange of sustainable knowledge and expertise between public and private sectors for effective implementation.
Research and Development Funding	Joint investment in research and development initiatives to innovate sustainable technologies in cement production.
Policy Alignment and Advocacy	Public-private alignment of policies and active advocacy for practical, sustainable regulations and standards.
Investment in Low-CO ₂ Technologies	Collaborative investment in low-CO technologies, supported by government incentives and private sector funding.
Infrastructure Development and Implementation	Establishing research centres, pilot projects, and facilities for large-scale implementation of sustainable cement technologies.
Capacity Building and Training	Creating training modules and skill development programs to ensure a competent workforce capable of implementing sustainability.
Sustainable Supply Chains	Promoting sustainability across the supply chain, from sourcing raw materials to efficient transportation and waste reduction.
Community Engagement and Awareness	Engaging communities and raising awareness about sustainable cement production through educational and outreach initiatives.

sustainability within the cement sector. The study by [Türkeli et al. \(2022\)](#) explored eco-cement transitions in the Netherlands, China, and Japan, shedding light on the differing trajectories and interventions in these countries. It highlighted that successful sustainable transitions required a cohesive approach involving policy formulation, technological innovation, and active private sector involvement. The comparative analysis underscored the importance of collaborative efforts involving both public and private stakeholders in enabling such transitions.

In India, [Marinelli and Janardhanan \(2022\)](#) emphasized the significance of green cement production and identified barriers to its implementation. They prioritized solutions using the best-worst method, stressing the need for policy interventions and incentives from the government to overcome these barriers. This highlighted the crucial role of public sector support in driving sustainability initiatives and fostering collaboration with the private sector. The study by [Stokke et al. \(2022\)](#) emphasized the role of green public procurement in promoting low-carbon cement with carbon capture and storage (CCS). It advocated for a supportive policy framework that incentivized the procurement of low-carbon cement, thus encouraging private sector investment and technological advancements. Public sector policies were identified as pivotal in steering the industry towards sustainability by creating a favorable market for eco-friendly cement. Additionally, [Mwiti Marangu et al. \(2023\)](#) provided five recommendations to accelerate sustainable solutions in cement and concrete through partnerships. Their suggestions included fostering interdisciplinary collaboration, promoting innovative technologies, and creating platforms for knowledge sharing. These recommendations underscored the need for multi-stakeholder partnerships, where the public sector could act as a catalyst in bringing various stakeholders together to work towards a common goal of sustainability.

The studies collectively emphasized that successful sustainable cement production necessitated collaboration between the public and private sectors. The public sector, through policies, incentives, and procurement strategies, could drive sustainability initiatives and provide a conducive environment for the private sector to invest in and adopt sustainable technologies. Collaboration fostered innovation, knowledge sharing, and the development of solutions to overcome barriers, ultimately propelling the cement industry towards a more sustainable future.

7. Addressing challenges and barriers

7.1. Technical challenges in implementing Low-CO₂ technologies

Implementing low-CO₂ technologies in the cement industry, while promising for sustainability, is accompanied by a spectrum of intricate technical challenges that demand focused attention for effective integration and impact. These challenges need to be effectively navigated to ensure the seamless adoption of eco-friendly technologies. [Table 10](#) provides a holistic view by coupling the challenges with potential mitigation strategies, providing a clear framework for addressing and overcoming each challenge associated with low-CO₂ cement technologies.

The transition to low-CO₂ technologies within the cement industry represents a critical endeavour to mitigate its environmental impact. Understanding and addressing the technical challenges in implementing these technologies is pivotal for a sustainable future. Several studies shed light on these challenges and offer valuable insights into the hurdles that need to be overcome to achieve a low-carbon future in the cement industry.

[Favier et al. \(2018\)](#) conducted a comprehensive assessment of the European Cement and Concrete Industry's technology in pursuit of full decarbonization by 2050. The study identified a pressing need for advancements in carbon capture and storage (CCS) technologies. A significant challenge lies in developing methods to capture and store CO₂ emissions economically and effectively at an industrial scale. [Schneider](#)

Table 10
Challenges and mitigation strategies in Low-CO₂ cement technologies.

Areas	Challenges	Mitigation Strategies
Technology Maturity and Scale-up	Taking prototypes to an industrial scale while ensuring cost-effectiveness.	<ul style="list-style-type: none"> - Collaborate with industry partners for scaling trials - Secure funding for large-scale implementation. - Utilise advanced simulation and modelling for predictive scaling.
Energy Efficiency and Performance	Reducing CO ₂ emissions without compromising energy efficiency or performance.	<ul style="list-style-type: none"> - Invest in research to develop more energy-efficient processes - Utilise waste heat recovery systems to improve energy efficiency. - Integrate AI and automation for real-time process optimisation.
Integration with Existing Infrastructure	Modifying or integrating new technologies into established cement plant infrastructure.	<ul style="list-style-type: none"> - Conduct thorough site assessments for seamless integration. - Collaborate with plant engineers to adapt existing structures. - Develop retrofitting strategies for smooth technology integration.
Process Complexity and Optimisation	Managing complexity introduced by new technologies and optimizing for efficiency.	<ul style="list-style-type: none"> - Invest in R&D to streamline processes and reduce complexity. - Use data analytics to identify optimisation opportunities. - Engage experts to conduct in-depth process audits and optimisations.
Carbon Capture and Storage (CCS)	Capturing and storing CO ₂ emissions economically and securely.	<ul style="list-style-type: none"> - Invest in research to improve capture technologies and reduce costs. - Identify suitable storage sites using geological assessments. - Collaborate with governments for supportive policies and funding.
Material Availability and Supply Chain	Ensuring a consistent supply of raw materials and managing the supply chain efficiently.	<ul style="list-style-type: none"> - Diversify sourcing locations to mitigate supply chain risks. - Engage in long-term contracts with material suppliers. - Promote circular economy practices for material recycling and sustainability.
Life Cycle Assessment and Environmental Impact	Conducting comprehensive assessments of environmental impact throughout a technology's lifecycle.	<ul style="list-style-type: none"> - Conduct regular and rigorous life cycle assessments (LCAs). - Collaborate with environmental experts to identify improvement areas. - Implement findings from LCAs to reduce environmental footprints.
Adaptability to Different Geographies	Ensuring technologies are effective and adaptable in diverse geographical contexts.	<ul style="list-style-type: none"> - Collaborate with local experts to understand regional nuances. - Tailor technology implementations to suit regional regulations and conditions. - Conduct extensive market research before deploying new technologies.

(2019) highlighted the necessity for innovative approaches to steer the cement industry towards a low-carbon future. One key technical challenge emphasized is the optimisation of energy consumption during cement production. Striking a balance between reduced CO₂ emissions and energy efficiency without compromising performance is a complex task that requires further research and innovative solutions.

Zajac et al. (2021) proposed a promising approach—CO₂ mineralization of demolished concrete wastes into a supplementary cementitious material. However, a notable challenge is scaling up this process from a laboratory to an industrial scale. Adapting the process to handle large quantities of demolished concrete waste efficiently is a significant technical hurdle. Chaudhury et al. (2023) presented strategies to achieve net-zero CO₂ emissions in the cement sector, highlighting the need for advanced alternative cementitious materials. The challenge is to develop materials that not only perform equivalently or better than traditional cement but are also economically viable for large-scale adoption. Wang et al. (2023) conducted a literature review on the historical trend and decarbonization pathway of China's cement industry, identifying the challenge of optimizing the clinker-to-cement ratio. Achieving a lower clinker-to-cement ratio is crucial for reducing CO₂ emissions, necessitating advancements in clinker substitution materials and alternative technologies.

Effectively addressing the technical challenges associated with integrating low-CO₂ technologies within the cement industry is fundamental to achieving sustainable and environmentally responsible cement production. The cement industry is a major contributor to global carbon emissions, making the implementation of low-CO₂ technologies a critical priority in combating climate change. These challenges encompass a spectrum of issues, including ensuring the technological maturity and scalability of promising concepts, optimizing energy efficiency without compromising performance, integrating new technologies with existing infrastructure, and effectively capturing and storing carbon emissions (CCS). Moreover, there's a need to navigate complexities in the production process, adapt to diverse geographical contexts, and evaluate the environmental impact through comprehensive life cycle assessments. To overcome these challenges, a collective and interdisciplinary approach is crucial. Collaborative research and knowledge sharing between public and private sectors, substantial funding for research and development, and supportive policy frameworks are vital components. By fostering innovation, investing in research, and aligning policies, the cement industry can transition towards a low-carbon future, contributing significantly to global sustainability efforts.

7.2. Infrastructure and investment barriers

Navigating the landscape of infrastructure and investment barriers is crucial for the successful adoption of low-CO₂ technologies in the cement industry, facilitating a shift towards sustainability. Table 11 summarises infrastructure and investment barriers for the adoption of low-CO₂ technologies in the cement industry. The table highlights major barriers to the adoption of low-CO₂ technologies in the cement industry. Cost-Intensive Technology Adoption underscores the high capital requirements and infrastructure modifications needed, posing initial hurdles. Financial Viability and ROI concerns emphasize the need for assured return on investment, aligning with operational savings and emission compliance. Access to Funding and Capital is a challenge for smaller enterprises due to perceived risks. Insufficient Incentives and Subsidies, Risks and Uncertainties in Technology Implementation, Skill Gaps, and Regulatory Dynamics present significant hurdles. Alignment with Existing Infrastructure and Lengthy Planning and Deployment Cycles further impede swift technology adoption. Addressing these barriers is crucial for successful industry-wide sustainability transformation.

Habert et al. (2010) highlighted the capital-intensive nature of the cement industry, which required substantial investments in machinery,

Table 11

Infrastructure and investment barriers in Low-CO₂ technology adoption.

Barriers	Description
Cost-Intensive Technology Adoption	Integration of low-CO ₂ technologies escalates the capital requirements of the already cost-intensive cement industry. Specialized equipment and infrastructure modifications further elevate costs, especially with novel processes or materials, posing initial implementation challenges.
Financial Viability and ROI	Cement manufacturers rigorously assess technology investments to ensure long-term financial viability. The uncertain timeline for ROI makes it challenging; they require assurance that initial high costs align with operational savings and future emission regulation compliance, justifying the investment.
Access to Funding and Capital	Small and medium-sized cement enterprises struggle to secure funds due to perceived risks associated with innovative technologies. Financial institutions' caution in extending loans for unproven or evolving technologies limits access to capital, impeding widespread adoption of low-CO ₂ technologies.
Insufficient Incentives and Subsidies	Governments play a pivotal role in encouraging low-CO ₂ technology adoption through incentives and subsidies. However, the varying availability and adequacy of these incentives across regions may deter technology adoption, particularly if the incentives do not align with the investment scale.
Risks and Uncertainties in Technology Implementation	Implementing innovative technologies entails inherent risks, leading cement companies to hesitate with unproven technologies. Uncertainties regarding performance, reliability, or the emergence of superior alternatives post-investment affect the decision-making process, posing a barrier to adoption.
Skill Gaps and Workforce Training	Transitioning to low-CO ₂ technologies demands a specialized workforce skilled in new areas such as advanced materials, renewable energy integration, or carbon capture. Skill gaps in the existing workforce necessitate investments in training and educational programs to bridge the expertise gap.
Dynamic Regulatory Landscape	The evolving regulatory environment concerning environmental policies can necessitate adjustments in adopted low-CO ₂ technologies or additional investments for compliance. The changing landscape adds complexity to long-term planning and investment decisions, impacting the choice of technologies for adoption.
Alignment with Existing Infrastructure	Existing cement plant infrastructures are optimised for traditional production processes. Seamless integration of low-CO ₂ technologies demands meticulous planning to ensure compatibility and efficiency. Retrofitting or modifying infrastructure while minimizing disruptions poses a significant challenge, requiring careful engineering and resource allocation.
Lengthy Planning and Deployment Cycles	The cement industry operates in a competitive market that demands rapid responses to changing demands. Lengthy planning and deployment cycles associated with integrating new technologies can hinder swift adoption. Cement companies face pressure to quickly adopt changes while being constrained by extended technology implementation timelines.

equipment, and facilities. Integrating low-CO₂ technologies amplified these costs due to specialized equipment and modifications to existing infrastructure. This factor was further accentuated by the potential involvement of novel processes or materials, adding to the initial implementation expenses. Rootzén and Johnsson (2017) emphasized

the importance of evaluating the financial viability and return on investment (ROI) of technology investments. Cement manufacturers faced the challenge of justifying the high initial costs through operational savings and compliance with future emission regulations.

One of the major hurdles faced by small and medium-sized cement enterprises, as outlined by [Karttunen et al. \(2021\)](#), was the difficulty in securing funds. Financial institutions often perceived innovative technologies as risky ventures, resulting in limited access to capital for projects involving unproven or evolving technologies. This lack of access to capital acted as a barrier and inhibited the potential widespread adoption of low-CO₂ technologies. Moreover, the study by [Rootzén et al. \(2020\)](#) underscored the role of government incentives and subsidies in encouraging technology adoption. However, the availability and adequacy of these incentives could vary across regions. The insufficiency or inconsistency of government support might have impeded timely and large-scale adoption of low-CO₂ technologies by cement manufacturers. The dynamic regulatory landscape, as discussed by [Rootzén et al. \(2020\)](#), presented another significant challenge. The evolving nature of environmental policies could have necessitated adjustments in adopted low-CO₂ technologies or additional investments for compliance. This regulatory uncertainty added complexity to long-term planning and investment decisions, impacting technology choices and strategies.

Overcoming these challenges required collaborative efforts involving governments, financial institutions, research organizations, and industry experts. Stable policies, tailored financial products, and insights into emerging technologies were essential components of a holistic approach that could have facilitated a smoother transition to low-CO₂ technologies in the cement industry.

7.3. Societal acceptance and behavioural factors

Societal acceptance and behavioural factors are pivotal in the transition towards sustainable practices. Public awareness, understanding, and perception of sustainable technologies significantly influence their adoption. Factors such as trust in innovation, consumer demand for eco-friendly products, and perceptions of cost-effectiveness play crucial roles. Effective policies aligning with societal expectations, economic incentives, educational programs, and stakeholder engagement enhance acceptance. Collaboration between industries, governments, and the public cultivates a culture of sustainability, driving behavioural shifts towards embracing environmentally friendly alternatives. Ultimately, societal acceptance forms the bedrock upon which sustainable technologies thrive, shaping a greener future. Addressing societal acceptance and behavioural factors is crucial for the successful implementation of low-CO₂ technologies in the cement industry.

- 1 **Public Awareness and Understanding:** A key challenge lies in ensuring that the general public comprehends the importance of transitioning to low-CO₂ technologies in the cement industry. Many individuals may not fully grasp the environmental impact of traditional cement production. Raising awareness about climate change, carbon footprints, and the role of sustainable cement production is essential to gain public support.
- 2 **Community Perceptions and Concerns:** Communities living near cement plants might have concerns about the implementation of new technologies. These concerns could range from fears about potential environmental or health impacts to worries about changes in the local economy. Addressing these concerns through transparent communication and providing credible information is crucial to gain community support.
- 3 **Consumer Preferences and Demand:** Consumer demand for sustainable products is a critical factor influencing the cement industry's direction. If consumers prioritize environmentally friendly products, the demand for low-CO₂ cement will rise, incentivizing manufacturers to invest in these technologies. Understanding and

influencing consumer preferences through marketing and education is vital.

- 4 **Technological Perceptions and Trust:** Trust in the effectiveness and safety of new technologies is paramount. The public and industry stakeholders need to trust that low-CO₂ technologies are reliable, efficient, and safe. Any negative perception or mistrust towards these technologies can hinder their widespread acceptance and uptake in the cement sector.
- 5 **Policy Alignment and Regulatory Support:** Societal acceptance is influenced by governmental policies and regulations. Clear and supportive policies that incentivize or mandate the adoption of low-CO₂ technologies provide a favorable environment for industry and public acceptance. Alignment between public policies and societal expectations is critical for fostering a positive attitude towards sustainable cement production.
- 6 **Incentives and Economic Factors:** Economic incentives, such as tax breaks for sustainable cement production, can significantly influence societal acceptance. If low-CO₂ technologies lead to cost savings that are passed on to consumers, this can drive acceptance and adoption. Economic viability and tangible benefits are key factors that influence societal attitudes towards change.
- 7 **Education and Advocacy:** Educational programs and advocacy efforts can play a vital role in altering societal perceptions and behaviours. Teaching about the environmental impact of traditional cement production and showcasing the benefits of sustainable alternatives can reshape public opinion and foster acceptance of low-CO₂ technologies.
- 8 **Collaboration and Stakeholder Involvement:** Involving various stakeholders, including local communities, environmental organizations, and industry experts, in the decision-making process can build a sense of ownership and acceptance. Engaging stakeholders and incorporating their perspectives can lead to more inclusive, well-informed decisions that garner broader societal support.

Overcoming these challenges involves concerted efforts from industry, governments, NGOs, and the public. Effective communication, targeted educational campaigns, transparent dialogues, and demonstrating the benefits of low-CO₂ technologies can collectively lead to increased societal acceptance and behavioural shifts, driving a sustainable future for the cement industry.

8. Future prospects and recommendations

8.1. Future trends and innovations in the cement industry

Future trends and innovations in the cement industry point towards sustainability and efficiency. Carbon capture and storage technologies are scaling to mitigate emissions, while next-gen clinker technologies explore alternatives like calcined clay. Electrification, powered by renewables, and green energy integration are on the rise. Digitalization through AI and IoT optimises processes, enhancing efficiency. Circular economy practices embrace recycled materials, and waste heat recovery minimises energy waste. Nanotechnology improves concrete properties, and additive manufacturing revolutionizes construction. Hybrid and integrated plants diversify production, and transparent life cycle assessments guide sustainable choices. These trends signify a sustainable, technology-driven future for cement production.

- 1 **Carbon Capture, Utilization, and Storage (CCUS) Scaling:** Scaling up CCUS technologies involves implementing more effective methods to capture carbon emissions during cement production. Innovations in capturing and storing captured carbon, such as using it for enhanced oil recovery or converting it into useful products like concrete, plastics, or fuels, will play a vital role. The development of cost-effective carbon capture

solutions that can be integrated seamlessly into cement plants is essential.

- 2 **Next-Generation Clinker Technologies:** Next-gen clinker technologies revolve around finding alternatives to traditional clinker production, a significant source of CO₂ emissions. Researchers are exploring the use of supplementary cementitious materials like calcined clay, which can partially or fully replace clinker. This shift aims to reduce the carbon intensity of cement by modifying the composition of clinker or finding suitable substitutes altogether.
- 3 **Electrification and Green Energy Integration:** The trend towards electrification involves shifting from fossil fuel-based energy sources to electricity, primarily sourced from renewables. Electric kilns and mills will replace traditional fossil-fuel-powered equipment, enabling the industry to reduce its carbon footprint. Integrating advanced energy storage solutions ensures a continuous and reliable power supply for cement production while decreasing reliance on non-renewable energy.
- 4 **Digitalization and Industry 4.0 Technologies:** The cement industry is increasingly embracing digital technologies to enhance efficiency and sustainability. Artificial Intelligence (AI) and the Internet of Things (IoT) optimise processes and predict maintenance needs, minimizing energy usage and waste. Digital twins, or virtual replicas of physical cement plants, aid in simulation and analysis, facilitating better decision-making for sustainable and efficient operations.
- 5 **Circular Economy and Sustainable Supply Chains:** Cement manufacturers are actively exploring circular economy practices. This includes utilizing recycled concrete as aggregate, incorporating industrial by-products like fly ash and slag as alternative raw materials, and creating closed-loop systems to minimise waste. Sustainable supply chains focus on responsible sourcing of raw materials and promoting a circular approach to resource utilization.
- 6 **Advanced Concrete Formulations:** Innovations in concrete formulations aim to improve its properties and sustainability. Self-healing concrete contains embedded bacteria that repair cracks autonomously, extending the lifespan of structures and reducing maintenance. High-performance concrete formulations reduce water usage and increase durability, contributing to sustainable construction practices.
- 7 **Waste Heat Recovery and Utilization:** Waste heat recovery systems capture and repurpose excess heat from cement production processes. This recovered heat can be utilised for power generation or to drive other industrial processes, significantly improving energy efficiency and reducing the overall carbon footprint of cement plants.
- 8 **Nanotechnology and Additive Manufacturing:** Nanotechnology is revolutionizing cement by incorporating nanomaterials to enhance its properties. Nano-modified cementitious materials are stronger, more durable, and possess self-cleaning properties. Additive manufacturing, particularly 3D printing, is gaining traction in the construction industry, allowing for the efficient use of cement-based materials in complex and precise structures.
- 9 **Hybrid and Integrated Cement Plants:** Hybrid cement plants combine traditional cement production with innovative processes, like electrolysis to produce clinker or renewable hydrogen as a heat source. Integrated facilities diversify their production by co-manufacturing cement and other products like green chemicals, utilizing the waste streams efficiently.
- 10 **Life Cycle Assessment and Transparency:** As sustainability gains prominence, comprehensive life cycle assessment tools are being developed to evaluate the environmental impact of cement throughout its lifecycle. Transparency in reporting environmental footprints, including carbon emissions, resource consumption, and ecological effects, allows stakeholders to make

informed decisions and hold the industry accountable for its environmental impact.

By focusing on these advancements, the cement industry can align with global sustainability goals, significantly reduce its carbon footprint, and contribute to a more environmentally conscious and responsible future. Collaborations, research funding, and supportive policies will accelerate the adoption of these innovations, ensuring a sustainable trajectory for the industry.

8.2. Recommendations for policymakers, industry stakeholders and researchers

8.2.1. Policymakers

Policymakers should establish specific, measurable, and time-bound carbon reduction targets for the cement industry. These targets should align with global climate goals, providing a clear trajectory for the industry's transition to sustainability. Incentives such as tax breaks, grants, and subsidies can significantly encourage cement companies to invest in sustainable technologies. Policymakers should design and implement financial mechanisms that reward sustainable practices and penalize carbon-intensive ones. Implementing and enforcing stringent environmental regulations that focus on carbon capture, energy efficiency, and sustainable sourcing of materials in cement production is crucial. This regulatory framework should create a level playing field for all industry players and drive the adoption of eco-friendly practices. Allocating funds for research and development in the cement sector, specifically targeting low-carbon technologies, is essential. Policymakers should facilitate collaboration between research institutions and the industry, ensuring that research outcomes are practically applicable. Policymakers should actively participate in international forums and agreements to harmonize standards and regulations across borders. Collaborative efforts can help share best practices and ensure a cohesive approach to tackling global sustainability challenges in the cement industry.

8.2.2. Industry stakeholders

To enhance the sustainability of cement companies, it is essential to prioritize research and development (R&D) by allocating a substantial portion of their budgets. This focus on innovation should aim at reducing carbon emissions and improving overall sustainability. The long-term benefits resulting from investment in R&D will not only be advantageous for the industry but also contribute positively to the environment. Collaboration within the industry is crucial for promoting sustainability. All stakeholders, including cement manufacturers and suppliers, should engage in sharing knowledge and pooling resources. This collaborative approach accelerates the development and adoption of sustainable practices and technologies, fostering a collective commitment to a greener future.

Transparency plays a vital role in building trust and showcasing the industry's dedication to environmental responsibility. Cement companies need to commit to transparently reporting their environmental impacts and efforts to adopt sustainable practices. This commitment not only fosters a positive public image but also demonstrates accountability for the industry's ecological footprint. Investing in the education and upskilling of the workforce is another key aspect of promoting sustainability. Training programs should be designed to inform employees about sustainable practices and technologies. An informed workforce is more likely to embrace and effectively implement sustainability initiatives, contributing to the overall success of environmental responsibility within the industry.

8.2.3. Researchers

To advance sustainability in cement production, researchers should prioritize the development of innovative technologies aimed at significantly reducing carbon emissions. This involves exploring alternative

raw materials, implementing carbon capture technologies, and optimizing energy-efficient processes to minimise the industry's overall environmental footprint. A crucial step in understanding and mitigating the environmental impact of cement production is the undertaking of comprehensive life cycle assessments. Researchers play a pivotal role in conducting these analyses, offering valuable insights that guide decision-makers in adopting the most sustainable practices across the entire life cycle of cement.

Collaborative research efforts, bringing together researchers and industry stakeholders, are essential for ensuring the practical applicability of academic studies to real-world challenges. This collaborative approach serves as a bridge between academic insights and practical implementation, expediting the integration of sustainable innovations in the cement industry. Active engagement in knowledge dissemination is paramount for researchers. Through publications, workshops, and partnerships, researchers can share their findings and insights with policymakers and industry professionals, contributing to informed decision-making and the widespread adoption of sustainable practices in the cement sector.

8.2.4. Cross-sector collaboration

Encouraging and facilitating partnerships between the public and private sectors to leverage each other's strengths in promoting sustainability becomes crucial. Joint initiatives have the potential to expedite the transition by combining government support with industry expertise and resources. Collaborating with financial institutions to develop specialized financial products that incentivize investment in sustainable cement technologies is a key strategy. Engaging the finance sector becomes instrumental in providing the necessary capital to fund sustainable projects effectively. Industry stakeholders, in collaboration, should undertake consumer awareness campaigns to educate the public about the benefits of using sustainable cement. Increasing consumer demand for eco-friendly products is expected to drive the industry towards the widespread adoption of sustainable practices.

8.3. Roadmap to a net-zero carbon cement sector

Through active collaboration among stakeholders such as governments, industry players, research institutions, and communities, the cement industry can seamlessly transition towards sustainability. By implementing the recommendations provided in the table, the industry can adopt low-CO₂ technologies, alternative raw materials, and fuels while addressing associated barriers like high costs and regulatory dynamics. This transformation is a significant stride towards reducing the industry's carbon emissions, promoting a more environmentally conscious future. The concerted efforts of all involved parties, coupled with innovative solutions and a shared commitment to sustainability, will propel the cement industry into a pivotal role in global climate action. This transition sets a sustainable precedent for other sectors to follow, amplifying the positive impact on our planet.

Table 12 outlines a comprehensive CO₂ roadmap divided into three distinct phases spanning from 2024 to 2050. In the Foundation phase (2024–2030), actions focus on policy development, investment in clean technologies, and public awareness campaigns to lay the groundwork for emission reduction. Acceleration (2031–2040) emphasizes scaling up renewable energy, decarbonizing transportation, and deploying carbon capture and storage technologies. The final phase, Net-Zero Transition (2041–2050), prioritizes aggressive emission reduction strategies, scaling up negative emissions technologies, and fostering international cooperation. This structured approach aims to achieve net-zero emissions by 2050 through targeted actions and key milestones across various sectors.

9. Conclusions and policy implications

In the face of an escalating global climate crisis, this comprehensive

Table 12
Roadmap to a net-zero carbon cement sector.

Timeline (Years)	Phase	Actions	Key Milestones/Targets
2024–2030	Foundation	Policy Development	Implement carbon pricing mechanisms, establish renewable energy targets.
		Investment in Clean Technologies	Allocate funding for research and development of renewable energy sources.
		Public Awareness and Education	Launch public awareness campaigns, provide incentives for sustainable practices.
2031–2040	Acceleration	Scaling Up Renewable Energy	Expand renewable energy infrastructure, invest in grid modernization.
		Decarbonizing Transportation	Incentivize electric vehicle adoption, expand public transportation networks.
		Carbon Capture and Storage (CCS)	Deploy CCS technologies, invest in CCUS research.
2041–2050	Net-Zero Transition	Emission Reduction Strategies	Implement aggressive emission reduction measures, promote sustainable land use practices.
		Negative Emissions Technologies	Scale up deployment of NETs, invest in research and development.
		International Cooperation	Collaborate with other countries, support developing countries in low-carbon transition.

roadmap serves as a beacon of hope and a strategic blueprint for an industry that has long grappled with its substantial environmental footprint. The cement industry, historically known for its carbon-intensive practices, is at a pivotal crossroads. It stands on the brink of transformation, guided by a collective determination to become a net-zero carbon sector. The urgency of addressing carbon emissions in cement production cannot be overstated. As the demand for infrastructure and construction materials continues to soar globally, so does the industry's carbon footprint. This roadmap underscores the critical need to decarbonize cement production, highlighting the far-reaching implications of its carbon emissions on climate change.

Central to this transformative journey are low-CO₂ emission technologies, which offer a ray of hope for an industry deeply entwined with carbon-intensive processes. From carbon capture and utilization to the integration of renewable energy sources, these technologies hold the promise of substantial emissions reductions. Alternative raw materials and fuels offer additional avenues for reducing the industry's reliance on traditional, high-emission sources.

Innovative approaches and emerging technologies, such as alkali-activated cements and biomimicry-inspired materials, represent the industry's commitment to embracing cutting-edge solutions. These innovations challenge conventional norms, offering more sustainable alternatives that not only reduce emissions but also improve performance and durability. Economic and policy considerations underscore the multifaceted nature of this transformation. Cost analysis and economic viability assessments illuminate the feasibility of sustainable practices, providing industry stakeholders with valuable insights into the economic aspects of change. Policymakers are encouraged to take a proactive role in shaping the industry's trajectory by implementing incentives, regulations, and collaborative initiatives that align with global sustainability goals.

Yet, the path to sustainability is not without its challenges and barriers. Technical hurdles, infrastructure limitations, and societal acceptance are formidable obstacles that require innovative solutions and

concerted efforts. These challenges serve as reminders that transformation is seldom easy but always necessary. The roadmap further illustrates the power of collective action and knowledge sharing through case studies and best practices. Success stories from within the industry demonstrate that change is possible and that sustainable practices can be implemented effectively.

Looking ahead, future prospects and recommendations cast a vision of a cement industry that not only survives but thrives in a sustainable world. By embracing these recommendations, policymakers, industry stakeholders, and researchers can collectively drive the transition toward a net-zero carbon cement sector. This is not just an environmental imperative; it is a strategic necessity, underpinned by the understanding that sustainability is not a choice but an imperative for the industry's long-term viability.

This paper acknowledges certain limitations. Firstly, the rapidly evolving landscape of low-CO₂ cement technologies may render some information outdated shortly after publication. Additionally, despite efforts to encompass diverse perspectives, data availability and regional variations might limit the comprehensiveness of the presented strategies and case studies. Furthermore, the paper primarily focuses on technological and policy aspects, potentially overlooking socio-cultural factors influencing the cement industry's transition. Finally, while case studies provide valuable insights, they may not fully capture the complex challenges and nuances inherent in widespread implementation. These limitations highlight the need for ongoing research and dynamic adaptation to achieve a net-zero carbon cement sector.

In closing, this roadmap is a testament to the cement industry's capacity for innovation, adaptability, and resilience. It is a testament to the industry's commitment to confronting its carbon legacy and shaping a sustainable future. As we embark on this transformative journey together, we do so with the knowledge that the net-zero carbon cement sector is not a distant dream but an attainable reality, one that is defined by sustainability, responsibility, and a profound commitment to safeguarding our planet for future generations.

CRedit authorship contribution statement

Salim Barbhuiya: Writing – review & editing, Writing – original draft, Formal analysis, Data curation, Conceptualization. **Bibhuti Bhushan Das:** Writing – review & editing. **Dibyendu Adak:** Writing – review & editing.

Declaration of competing Interest

The authors declare that they have no known competing financial interests or personal relationships that could have appeared to influence the work reported in this paper.

Data availability

Data will be made available on request.

References

- Ahmed, M., Bashar, I., Alam, S.T., Wasi, A.I., Jerin, I., Khatun, S., Rahman, M., 2021. An overview of Asian cement industry: environmental impacts, research methodologies and mitigation measures. *Sustain. Prod. Consum.* 28, 1018–1039.
- Al-Ghussain, L., Ahmed, H., Haneef, F., 2018. Optimization of hybrid PV-wind system: case study Al-Tafilah cement factory, Jordan. *Sustain. Energy Technol. Assessments* 30, 24–36.
- Ali, M.B., Saidur, R., Hossain, M.S., 2011. A review on emission analysis in cement industries. *Renew. Sustain. Energy Rev.* 15 (5), 2252–2261.
- Amran, M., Makul, N., Fediuk, R., Lee, Y.H., Vatin, N.I., Lee, Y.Y., Mohammed, K., 2022. Global carbon recoverability experiences from the cement industry. *Case Stud. Constr. Mater.* 17, e01439.
- Atsonios, K., Grammelis, P., Antiohos, S.K., Nikolopoulos, N., Kakaras, Em., 2015. Integration of calcium looping technology in existing cement plant for CO₂ capture: process modeling and technical considerations. *Fuel* 153, 210–223.
- Benhelal, E., Alfi, M., Osanloo, M., Dehghan, A., 2013. Global strategies and potentials to curb CO₂ emissions in cement industry. *J. Clean. Prod.* 51, 142–161.
- Benhelal, E., Shamsaei, E., Rashid, M.I., 2021. Challenges against CO₂ abatement strategies in the cement industry: a review. *J. Environ. Sci.* 104, 84–101.
- Bolt, A., Dincer, I., Agelin-Chaab, M., 2023. Design of a multigenerational energy system with hydrogen production for clean cement plants. *J. Clean. Prod.* 405, 137025.
- Busch, T., Klee, H., Hoffmann, V.H., 2017. Curbing greenhouse gas emissions on a sectoral basis: the Cement Sustainability Initiative. *Corporate responses to climate change* 204–219.
- Buttinelli, M., Procesi, M., Cantucci, B., Quattrocchi, F., Boschi, E., 2011. The geodatabase of caprock quality and deep saline aquifers distribution for geological storage of CO₂ in Italy. *Energy* 36 (5), 2968–2983.
- Cagiao, J., Gómez, B., Doménech, J.L., Mainar, S.G., Lanza, H.G., 2011. Calculation of the corporate carbon footprint of the cement industry by the application of MC3 methodology. *Ecol. Indicat.* 11 (6), 1526–1540.
- Carl, J., Fedor, D., 2016. Tracking global carbon revenues: a survey of carbon taxes versus cap-and-trade in the real world. *Energy Pol.* 96, 50–77.
- Chatterjee, A., Sui, T., 2019. Alternative fuels—effects on clinker process and properties. *Cement Concr. Res.* 123, 105777.
- Chaudhury, R., Sharma, U., Thapliyal, P.C., Singh, L.P., 2023. Low-CO₂ emission strategies to achieve net zero target in cement sector. *J. Clean. Prod.*, 137466.
- Chen, Y.H., Wang, C., Nie, P.Y., Chen, Z.R., 2020. A clean innovation comparison between carbon tax and cap-and-trade system. *Energy Strategy Rev.* 29, 100483.
- Cloete, S., Giuffrida, A., Romano, M.C., Zaabout, A., 2020. Economic assessment of the swing adsorption reactor cluster for CO₂ capture from cement production. *J. Clean. Prod.* 275, 123024.
- Coffetti, D., Crotti, E., Gazzaniga, G., Carrara, M., Pastore, T., Coppola, L., 2022. Pathways towards sustainable concrete. *Cement Concr. Res.* 154, 106718.
- Cook, G., Ponsard, J.P., 2011. A proposal for the renewal of sectoral approaches building on the Cement Sustainability Initiative. *Clim. Pol.* 11 (5), 1246–1256.
- Cormos, A.M., Cormos, C.C., 2017. Reducing the carbon footprint of cement industry by post-combustion CO₂ capture: techno-economic and environmental assessment of a CCS project in Romania. *Chem. Eng. Res. Des.* 123, 230–239.
- da Silva Rocha, T., Dias, D.P., França, F.C.C., de Salles Guerra, R.R., de Oliveira, L.R.D.C., 2018. Metakaolin-based geopolymers mortars with different alkaline activators (Na⁺ and K⁺). *Construct. Build. Mater.* 178, 453–461.
- De Lena, E., Spinelli, M., Gatti, M., Scaccabarozzi, R., Campanari, S., Consonni, S., Cinti, G., Romano, M.C., 2019. Techno-economic analysis of calcium looping processes for low CO₂ emission cement plants. *Int. J. Greenh. Gas Control* 82, 244–260.
- Dhar, S., Pathak, M., Shukla, P.R., 2020. Transformation of India's steel and cement industry in a sustainable 1.5 C world. *Energy Pol.* 137, 111104.
- Diego, M.E., Arias, B., Abanades, J.C., 2016. Analysis of a double calcium loop process configuration for CO₂ capture in cement plants. *J. Clean. Prod.* 117, 110–121.
- Di Filippo, J., Karpman, J., DeShazo, J.R., 2019. The impacts of policies to reduce CO₂ emissions within the concrete supply chain. *Cement Concr. Compos.* 101, 67–82.
- Erans, M., Jeremias, M., Zheng, L., Yao, J.G., Blamey, J., Manovic, V., Fennell, P.S., Anthony, E.J., 2018. Pilot testing of enhanced sorbents for calcium looping with cement production. *Appl. Energy* 225, 392–401.
- Favier, A., De Wolf, C., Scrivener, K., Habert, G., 2018. A Sustainable Future for the European Cement and Concrete Industry: Technology Assessment for Full Decarbonisation of the Industry by 2050. ETH Zurich.
- Fennell, P.S., Davis, S.J., Mohammed, A., 2021. Decarbonizing cement production. *Joule* 5 (6), 1305–1311.
- Ferrario, D., Stendardo, S., Verda, V., Lanzini, A., 2023. Solar-driven calcium looping system for carbon capture in cement plants: process modelling and energy analysis. *J. Clean. Prod.* 394, 136367.
- Gale, J., 2004. Geological storage of CO₂: what do we know, where are the gaps and what more needs to be done? *Energy* 29 (9–10), 1329–1338.
- Galvez-Martos, J.L., Chaliulina, R., Medina-Martos, E., Elhoweris, A., Hakki, A., Mwanda, J., Al-Horr, Y., 2021. Eco-efficiency of a novel construction material produced by carbon capture and utilization. *J. CO₂ Util.* 49, 101545.
- Gao, T., Shen, L., Shen, M., Liu, L., Chen, F., 2016. Analysis of material flow and consumption in cement production process. *J. Clean. Prod.* 112, 553–565.
- Georgiopoulou, M., Lyberatos, G., 2018. Life cycle assessment of the use of alternative fuels in cement kilns: a case study. *J. Environ. Manag.* 216, 224–234.
- Gielen, D., Boshell, F., Saygin, D., 2016. Climate and energy challenges for materials science. *Nat. Mater.* 15 (2), 117–120.
- Global Carbon Project, 2022. Annual CO₂ emissions from cement. Retrieved from <https://ourworldindata.org/grapher/annual-co2-cement>. (Accessed 27 September 2023).
- Guo, Y., Luo, L., Liu, T., Hao, L., Li, Y., Liu, P., Zhu, T., 2024. A review of low-carbon technologies and projects for the global cement industry. *J. Environ. Sci.* 136, 682–697.
- Habert, G., Billard, C., Rossi, P., Chen, C., Roussel, N., 2010. Cement production technology improvement compared to factor 4 objectives. *Cement Concr. Res.* 40 (5), 820–826.
- Hanifa, M., Ansary, M.A., Mahmud, S., Shaikh, F.N., 2023. A review on CO₂ capture and sequestration in the construction industry: emerging approaches and commercialised technologies. *J. CO₂ Util.* 67, Article 102292.
- Hellmann, J.J., Byers, J.E., Bierwagen, B.G., Dukes, J.S., 2008. Five potential consequences of climate change for invasive species. *Conserv. Biol.* 22 (3), 534–543.
- Heubbaum, H., Biermann, F., 2015. Integrating global energy and climate governance: the changing role of the International Energy Agency. *Energy Pol.* 87, 229–239.

- Hornberger, M., Moreno, J., Schmid, M., Scheffknecht, G., 2021. Experimental investigation of the calcination reactor in a tail-end calcium looping configuration for CO₂ capture from cement plants. *Fuel* 284, 118927.
- Hornberger, M., Moreno, J., Schmid, M., Scheffknecht, G., 2020. Experimental investigation of the carbonation reactor in a tail-end Calcium Looping configuration for CO₂ capture from cement plants. *Fuel Process. Technol.* 210, 106557.
- Hossain, M.U., Poon, C.S., Lo, I.M., Cheng, J.C., 2017. Comparative LCA on using waste materials in the cement industry: a Hong Kong case study. *Resour. Conserv. Recycl.* 120, 199–208.
- Hossain, M.U., Poon, C.S., Wong, M.Y.K., Khine, A., 2019. Techno-environmental feasibility of wood waste derived fuel for cement production. *J. Clean. Prod.* 230, 663–671.
- Huntzinger, D.N., Eatmon, T.D., 2009. A life-cycle assessment of Portland cement manufacturing: comparing the traditional process with alternative technologies. *J. Clean. Prod.* 17 (7), 668–675.
- Huovila, A., Pietilä, P., Heinonen, J., 2022. Carbon-neutral cities: critical review of theory and practice. *J. Clean. Prod.*, 130912.
- Ighalo, J.O., Adeniyi, A.G., 2020. A perspective on environmental sustainability in the cement industry. *Waste Disposal & Sustainable Energy* 2 (3), 161–164.
- Imbabi, M.S., Carrigan, C., McKenna, S., 2012. Trends and developments in green cement and concrete technology. *International Journal of Sustainable Built Environment* 1 (2), 194–216.
- Ishak, S.A., Hashim, H., 2015. Low carbon measures for cement plant—a review. *J. Clean. Prod.* 103, 260–274.
- Jacoby, K.D., 2009. Energy security: conceptualization of the international energy agency (IEA). In: *Facing Global Environmental Change: Environmental, Human, Energy, Food, Health and Water Security Concepts*. Springer Berlin Heidelberg, Berlin, Heidelberg, pp. 345–354.
- Jafari, M., Cao, S.C., Jung, J., 2017. Geological CO₂ sequestration in saline aquifers: implication on potential solutions of China's power sector. *Resour. Conserv. Recycl.* 121, 137–155.
- Jamali, D.H., Noorpoor, A., 2019. Optimization of a novel solar-based multi-generation system for waste heat recovery in a cement plant. *J. Clean. Prod.* 240, 117825.
- Karttunen, E., Tsytsyna, E., Lintukangas, K., Rintala, A., Abdulkareem, M., Havukainen, J., Nuortila-Jokinen, J., 2021. Toward environmental innovation in the cement industry: a multiple-case study of incumbents and new entrants. *J. Clean. Prod.* 314, 127981.
- Kashani, A., Provis, J.L., Qiao, G.G., van Deventer, J.S., 2014. The interrelationship between surface chemistry and rheology in alkali activated slag paste. *Construct. Build. Mater.* 65, 583–591.
- Khaqqi, K.N., Sikorski, J.J., Hadinoto, K., Kraft, M., 2018. Incorporating seller/buyer reputation-based system in blockchain-enabled emission trading application. *Appl. Energy* 209, 8–19.
- Khoshevis Yazdi, S., Shakouri, B., 2010. The effects of climate change on aquaculture. *Int. J. Environ. Sustain. Dev.* 1 (5), 378.
- Klee, H., 2004. Briefing: the cement sustainability initiative. *Proceedings of the Institution of Civil Engineers-Engineering Sustainability* 157 (1), 9–11 (Thomas Telford Ltd).
- Kusuma, R.T., Hiremath, R.B., Rajesh, P., Kumar, B., Renukappa, S., 2022. Sustainable transition towards biomass-based cement industry: a review. *Renew. Sustain. Energy Rev.* 163, 112503.
- Lamas, W. de Q., Palau, J.C.F., Camargo, J. R. de, 2013. Waste materials co-processing in cement industry: ecological efficiency of waste reuse. *Renew. Sustain. Energy Rev.* 19, 200–207.
- Leeson, D., Mac Dowell, N., Shah, N., Petit, C., Fennell, P.S., 2017. A Techno-economic analysis and systematic review of carbon capture and storage (CCS) applied to the iron and steel, cement, oil refining, and pulp and paper industries, as well as other high purity sources. *Int. J. Greenh. Gas Control* 61, 71–84.
- Li, Q., Liu, Z., Chen, W., Yuan, B., Liu, X., Chen, W., 2019. A novel bio-inspired bone-mimic self-healing cement paste based on hydroxyapatite formation. *Cement Concr. Compos.* 104, 103357.
- Li, Z., de Souza, L.R., Litina, C., Markaki, A.E., Al-Tabbaa, A., 2020. A novel biomimetic design of a 3D vascular structure for self-healing in cementitious materials using Murray's law. *Mater. Des.* 190, 108572.
- Li, W., Wang, L., Li, Y., Liu, B., 2021. A blockchain-based emissions trading system for the road transport sector: policy design and evaluation. *Clim. Pol.* 21 (3), 337–352.
- Lima, L., Barbosa, F.L., Soares, G., Silva, V.S., Bragança, L., 2021. Sustainability in the construction industry: a systematic review of the literature. *J. Clean. Prod.* 289, 125730.
- Liu, S., Chen, Y., Li, X., Wang, L., Du, H., 2023. Development of bio-inspired cement-based material by magnetically aligning graphene oxide nanosheets in cement paste. *Construct. Build. Mater.* 369, 130545.
- Liu, L., Cheng, S.Y., Li, J.B., Huang, Y.F., 2007. Mitigating environmental pollution and impacts from fossil fuels: the role of alternative fuels. *Energy Sources, Part A* 29 (12), 1069–1080.
- Madlool, N.A., Saidur, R., Hossain, M.S., Rahim, N.A., 2011. A critical review on energy use and savings in the cement industries. *Renew. Sustain. Energy Rev.* 15 (4), 2042–2060.
- Magli, F., Spinelli, M., Fantini, M., Romano, M.C., Gatti, M., 2022. Techno-economic optimization and off-design analysis of CO₂ purification units for cement plants with oxyfuel-based CO₂ capture. *Int. J. Greenh. Gas Control* 115, 103591.
- Mahasanen, N., Smith, S., Humphreys, K., 2003. The cement industry and global climate change: current and potential future cement industry CO₂ emissions. In: *Greenhouse Gas Control Technologies-6th International Conference*. Pergamon, pp. 995–1000.
- Marinelli, M., Janardhanan, M., 2022. Green cement production in India: prioritization and alleviation of barriers using the best-worst method. *Environ. Sci. Pollut. Control Ser.* 29 (42), 63988–64003.
- Meinshausen, M., Lewis, J., McGlade, C., Gütschow, J., Nicholls, Z., Burdon, R., et al., 2022. Realization of Paris Agreement pledges may limit warming just below 2°C. *Nature* 604 (7905), 304–309.
- Mikulčić, H., Klemes, J.J., Vujanović, M., Urbanec, K., Duić, N., 2016. Reducing greenhouse gases emissions by fostering the deployment of alternative raw materials and energy sources in the cleaner cement manufacturing process. *J. Clean. Prod.* 136, 119–132.
- Miller, S.A., Habert, G., Myers, R.J., Harvey, J.T., 2021. Achieving net zero greenhouse gas emissions in the cement industry via value chain mitigation strategies. *One Earth* 4 (10), 1398–1411.
- Mishra, U.C., Sarsaiya, S., Gupta, A., 2022. A systematic review of the impact of cement industries on the natural environment. *Environ. Sci. Pollut. Control Ser.* 29 (13), 18440–18451.
- Mokrzycki, E., Uliasz-Bocheńczyk, A., 2003. Alternative fuels for the cement industry. *Appl. Energy* 74 (1–2), 95–100.
- Mwiti Marangu, J., Marsh, A.T., Panesar, D.K., Radebe, N.W., Regodon Puyalto, A., Schmidt, W., Valentini, L., 2023. Five recommendations to accelerate sustainable solutions in cement and concrete through partnership. *RILEM Technical Letters* 8, 1–11.
- Narassimhan, E., Gallagher, K.S., Koester, S., Alejo, J.R., 2018. Carbon pricing in practice: a review of existing emissions trading systems. *Clim. Pol.* 18 (8), 967–991.
- Norouzi, M., Chaïra, M., Cabeza, L.F., Jiménez, L., Boer, D., 2021. Circular economy in the building and construction sector: a scientific evolution analysis. *J. Build. Eng.* 44, 102704.
- Nwaoha, C., Beaulieu, M., Tontiwachwuthikul, P., Gibson, M.D., 2018. Techno-economic analysis of CO₂ capture from a 1.2 million MTPA cement plant using AMP-PZ-MEA blend. *Int. J. Greenh. Gas Control* 78, 400–412.
- Oberthür, S., Khandekar, G., Wyns, T., 2021. Global governance for the decarbonization of energy-intensive industries: great potential underexploited. *Earth System Governance* 8, 100072.
- Oberschelp, C., Pfister, S., Hellweg, S., 2023. Global site-specific health impacts of fossil energy, steel mills, oil refineries and cement plants. *Sci. Rep.* 13 (1), 13708.
- Obrist, M.D., Kannan, R., Schmidt, T.J., Kober, T., 2021. Decarbonization pathways of the Swiss cement industry towards net-zero emissions. *J. Clean. Prod.* 288, 125413.
- Oh, D.Y., Noguchi, T., Kitagaki, R., Park, W.J., 2014. CO₂ emission reduction by reuse of building material waste in the Japanese cement industry. *Renew. Sustain. Energy Rev.* 38, 796–810.
- Osland, M.J., Enwright, N.M., Day, R.H., Gabler, C.A., Stagg, C.L., Grace, J.B., 2016. Beyond just sea-level rise: considering macroclimatic drivers within coastal wetland vulnerability assessments to climate change. *Global Change Biol.* 22 (1), 1–11.
- Ostovari, H., Müller, L., Skocek, J., Bardow, A., 2021. From unavoidable CO₂ source to CO₂ sink? A cement industry based on CO₂ mineralization. *Environ. Sci. Technol.* 55 (8), 5212–5223.
- Panos, E., Kannan, R., Hirschberg, S., Kober, T., 2023. An assessment of energy system transformation pathways to achieve net-zero carbon dioxide emissions in Switzerland. *Communications Earth & Environment* 4 (1), 157.
- Paolella, M.S., Taschini, L., 2008. An econometric analysis of emission allowance prices. *J. Bank. Finance* 32 (10), 2022–2032.
- Pardo, N., Moya, J.A., Mercier, A., 2011. Prospective on the energy efficiency and CO₂ emissions in the EU cement industry. *Energy* 36 (5), 3244–3254.
- Patil, M.R., Sawant, P., 2014. Corporate social responsibility, performance and sustainability reporting of Shree Cement Company in India: a case study. *J. High Technol. Manag. Res.* 3 (4), 74–87.
- Plaza, M.G., Martínez, S., Rubiera, F., 2020. CO₂ capture, use, and storage in the cement industry: state of the art and expectations. *Energies* 13 (21), 5692.
- Poudyal, L., Adhikari, K., 2021. Environmental sustainability in cement industry: an integrated approach for green and economical cement production. *Resources, Environment and Sustainability* 4, 100024.
- Power, I.M., Dipple, G.M., Francis, P.S., 2017. Assessing the carbon sequestration potential of magnesium oxychloride cement building materials. *Cement Concr. Compos.* 78, 97–107.
- Proaño, L., Sarmiento, A.T., Figueredo, M., Cobo, M., 2020. Techno-economic evaluation of indirect carbonation for CO₂ emissions capture in cement industry: a system dynamics approach. *J. Clean. Prod.* 263, 121457.
- Rahman, A., Rasul, M.G., Khan, M.M.K., Sharma, S., 2015. Recent development on the uses of alternative fuels in cement manufacturing process. *Fuel* 145, 84–99.
- Rasheed, R., Tahir, F., Afzaal, M., Ahmad, S.R., 2022. Decomposition analytics of carbon emissions by cement manufacturing—a way forward towards carbon neutrality in a developing country. *Environ. Sci. Pollut. Control Ser.* 29 (32), 49429–49438.
- Ren, M., Ma, T., Fang, C., Liu, X., Guo, C., Zhang, S., et al., 2023. Negative emission technology is key to decarbonizing China's cement industry. *Appl. Energy* 329, 120254.
- Rehan, R., Nehdi, M., 2005. Carbon dioxide emissions and climate change: policy implications for the cement industry. *Environ. Sci. Pol.* 8 (2), 105–114.
- Rissman, J., Bataille, C., Masanet, E., Aden, N., Morrow III, W.R., Zhou, N., et al., 2020. Technologies and policies to decarbonize global industry: review and assessment of mitigation drivers through 2070. *Appl. Energy* 266, 114848.
- Rogelj, J., Den Elzen, M., Höhne, N., Fransen, T., Fekete, H., Winkler, H., et al., 2016. Paris Agreement climate proposals need a boost to keep warming well below 2°C. *Nature* 534 (7609), 631–639.
- Rogelj, J., Huppmann, D., Krey, V., Riahi, K., Clarke, L., Gidden, M., et al., 2019. A new scenario logic for the Paris Agreement long-term temperature goal. *Nature* 573 (7774), 357–363.

- Rolfe, A., Huang, Y., Haaf, M., Pita, A., Rezvani, S., Dave, A., Hewitt, N.J., 2018. Technical and environmental study of calcium carbonate looping versus oxy-fuel options for low CO₂ emission cement plants. *Int. J. Greenh. Gas Control* 75, 85–97.
- Rootzén, J., Johnsson, F., 2017. Managing the costs of CO₂ abatement in the cement industry. *Clim. Pol.* 17 (6), 781–800.
- Rootzén, J., Karlsson, L., Johnsson, F., Kadefors, A., Uppenberg, S., 2020. Supply-chain collective action towards zero CO₂ emissions in infrastructure construction: mapping barriers and opportunities. In: *IOP Conference Series: Earth and Environmental Science*. IOP Publishing, 042064. Vol. 588, No. 4.
- Ryu, G.S., Lee, Y.B., Koh, K.T., Chung, Y.S., 2013. The mechanical properties of fly ash-based geopolymer concrete with alkaline activators. *Construct. Build. Mater.* 47, 409–418.
- Salas, D.A., Ramirez, A.D., Rodríguez, C.R., Petroche, D.M., Boero, A.J., Duque-Rivera, J., 2016. Environmental impacts, life cycle assessment and potential improvement measures for cement production: a literature review. *J. Clean. Prod.* 113, 114–122.
- Schakel, W., Hung, C.R., Tokheim, L.A., Strömman, A.H., Worrell, E., Ramírez, A., 2018. Impact of fuel selection on the environmental performance of post-combustion calcium looping applied to a cement plant. *Appl. Energy* 210, 75–87.
- Schneider, M., 2015. Process technology for efficient and sustainable cement production. *Cement Concr. Res.* 78, 14–23.
- Schneider, M., 2019. The cement industry on the way to a low-carbon future. *Cement Concr. Res.* 124. Article 105792.
- Schneider, M., Romer, M., Tschudin, M., Bolio, H., 2011. Sustainable cement production—present and future. *Cement Concr. Res.* 41 (7), 642–650.
- Schleussner, C.F., Rogelj, J., Schaeffer, M., Lissner, T., Licker, R., Fischer, E.M., et al., 2016. Science and policy characteristics of the Paris Agreement temperature goal. *Nat. Clim. Change* 6 (9), 827–835.
- Science & Nature, 2022. Cement carbon dioxide emissions quietly double in 20 years. <https://news.wttw.com/2022/06/22/cement-carbon-dioxide-emissions-quietly-double-20-years>. (Accessed 27 September 2023).
- Scrivener, K., Martirena, F., Bishnoi, S., Maity, S., 2018. Calcined clay limestone cements (LC3). *Cement Concr. Res.* 114, 49–56.
- Segura, I.P., Ranjbar, N., Damo, A.J., Jensen, L.S., Canut, M., Jensen, P.A., 2023. A review: alkali-activated cement and concrete production technologies available in the industry. *Heliyon* 9 (5), e15718.
- Seku, A., Somani, R., 2014. Environmental accounting—A case study of cement sector in India. *International Journal of Innovative Research and Development* 3 (12), 447–460.
- Shen, L., Gao, T., Zhao, J., Wang, L., Wang, L., Liu, L., et al., 2014. Factory-level measurements on CO₂ emission factors of cement production in China. *Renew. Sustain. Energy Rev.* 34, 337–349.
- Spinelli, M., Martínez, I., Romano, M.C., 2018. One-dimensional model of entrained-flow carbonator for CO₂ capture in cement kilns by Calcium looping process. *Chem. Eng. Sci.* 191, 100–114.
- Stokke, R., Kristoffersen, F.S., Stamland, M., Holmen, E., Hamdan, H., De Boer, L., 2022. The role of green public procurement in enabling low-carbon cement with CCS: an innovation ecosystem perspective. *J. Clean. Prod.* 363, 132451.
- Tan, C., Yu, X., Guan, Y., 2022. A technology-driven pathway to net-zero carbon emissions for China's cement industry. *Appl. Energy* 325, 119804.
- Telesca, A., Calabrese, D., Marroccoli, M., Tomasulo, M., Valenti, G.L., Duelli, G., Montagnaro, F., 2014. Spent limestone sorbent from calcium looping cycle as a raw material for the cement industry. *Fuel* 118, 202–205.
- Teske, S., Niklas, S., Talwar, S., 2022. Decarbonisation pathways for industries. In: *Achieving the Paris Climate Agreement Goals: Part 2: Science-Based Target Setting for the Finance Industry—Net-Zero Sectoral 1.5° C Pathways for Real Economy Sectors*. Springer International Publishing, Cham, pp. 81–129.
- Tregambi, C., Solimene, R., Montagnaro, F., Salatino, P., Marroccoli, M., Ibris, N., Telesca, A., 2018. Solar-driven production of lime for ordinary Portland cement formulation. *Sol. Energy* 173, 759–768.
- Türkeli, S., Huang, B., Ohnishi, S., Kemp, R., 2022. Issues, interventions, and innovations in the cement industry: a comparative trajectory analysis of eco-cement transitions in The Netherlands, China, and Japan. In: *Circular Economy and Sustainability*. Elsevier, pp. 545–566.
- Uratani, J.M., Griffiths, S., 2023. A forward looking perspective on the cement and concrete industry: implications of growth and development in the Global South. *Energy Res. Social Sci.* 97, 102972.
- Vasiliu, L., Gencel, O., Damian, I., Harja, M., 2023. Capitalization of tires waste as derived fuel for sustainable cement production. *Sustain. Energy Technol. Assessments* 56, 103104.
- Van de Graaf, T., 2012. Obsolete or resurgent? The International Energy Agency in a changing global landscape. *Energy Pol.* 48, 233–241.
- Wang, Y., Yi, H., Tang, X., Wang, Y., An, H., Liu, J., 2023. Historical trend and decarbonization pathway of China's cement industry: a literature review. *Sci. Total Environ.*, 164580.
- Wang, S., Lu, J., Li, W., Li, J., Hu, Z., 2006. Modeling of pulverized coal combustion in cement rotary kiln. *Energy Fuels* 20 (6), 2350–2356.
- Xi, F., Davis, S.J., Ciais, P., Crawford-Brown, D., Guan, D., Pade, C., et al., 2016. Substantial global carbon uptake by cement carbonation. *Nat. Geosci.* 9 (12), 880–883.
- Xu, T., Galama, T., Sathaye, J., 2013. Reducing carbon footprint in cement material making: characterizing costs of conserved energy and reduced carbon emissions. *Sustain. Cities Soc.* 9, 54–61.
- Xu, J.H., Fleiter, T., Fan, Y., Eichhammer, W., 2014. CO₂ emissions reduction potential in China's cement industry compared to IEA's Cement Technology Roadmap up to 2050. *Appl. Energy* 130, 592–602.
- Zajac, M., Skocek, J., Skibsted, J., Haha, M.B., 2021. CO₂ mineralization of demolished concrete wastes into a supplementary cementitious material—a new CCU approach for the cement industry. *RILEM Technical Letters* 6, 53–60.
- Zhang, W., Maleki, A., Khajeh, M.G., Zhang, Y., Mortazavi, S.M., Vassel-Be-Hagh, A., 2019. A novel framework for integrated energy optimization of a cement plant: an industrial case study. *Sustain. Energy Technol. Assessments* 35, 245–256.
- Zhang, Z., Huisingh, D., 2017. Carbon dioxide storage schemes: technology, assessment and deployment. *J. Clean. Prod.* 142, 1055–1064.
- Zhao, X.G., Jiang, G.W., Nie, D., Chen, H., 2016. How to improve the market efficiency of carbon trading: a perspective of China. *Renew. Sustain. Energy Rev.* 59, 1229–1245.
- Zhi, X., An, X., 2023. Low carbon technology roadmap of China cement industry. *Journal of Sustainable Cement-Based Materials* 12 (6), 771–774.